

Vortex Flowmeter
digitalYEWFLO



Vortex Flowmeter

digitalYEWFLO *Series*

Bulletin 01F06A02-00E

www.yokogawa.com/fld

vigilantplant.[®]
The clear path to operational excellence

YOKOGAWA 

Unrivaled Performance, Functionality

digital YEW FLO Series

Simple body construction for easy installation and high level of safety



Standard Type /
Multi-variable Type

Reduced Bore Type

High Process Temperature /
Cryogenic Type

Large Size (400 mm)

Measurement principle

When a shedder bar is placed in a flow, Karman vortices are generated on the downstream side of the bar. The Karman vortices are detected by two piezoelectric elements installed in the upper part of the shedder bar. The vortex frequency is proportional to the flow velocity in a specific range of Reynolds numbers. Therefore, flow velocity or flow rate can be determined by measuring vortex frequency.

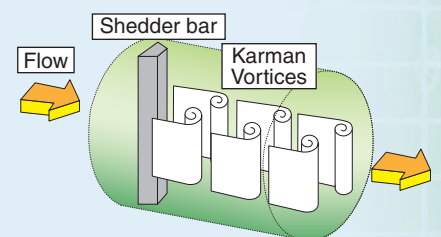

Features of the Vortex Flowmeter

- Easy installation, with flange or wafer process connections.
- No zero adjustment.
- No moving parts make Vortex Flowmeters highly durable and reliable.
- The sensing element and bluff body are combined in a single shedder bar, minimizing the pressure loss. The flowmeter is leak-free with a high degree of safety.
- Robust construction of the shedder bar makes measurement at high temperatures (max. 450°C) and high pressure possible.

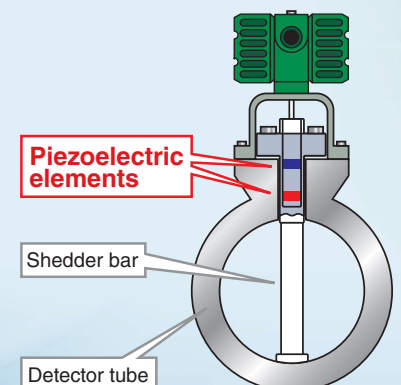

Functionality and Ease of Use



Standard Type

Yokogawa's proprietary filter (SSP) for digital signal processing analyzes vortex signals and automatically selects the optimum settings for the best possible measurement.



Noise Reduction

Noise caused by strong piping vibration may affect the accuracy of vortex frequency detection. The two piezoelectric elements in the digitalYEWFLOW are installed in a configuration that is polarized, so they are not affected by vibration in the flow or vertical directions. The noise of vortex (lift)-direction vibration is reduced by adjusting the outputs of the piezoelectric elements. Combining these features with the Spectral Signal Processing (SSP) function provides optimum and stable measurement.

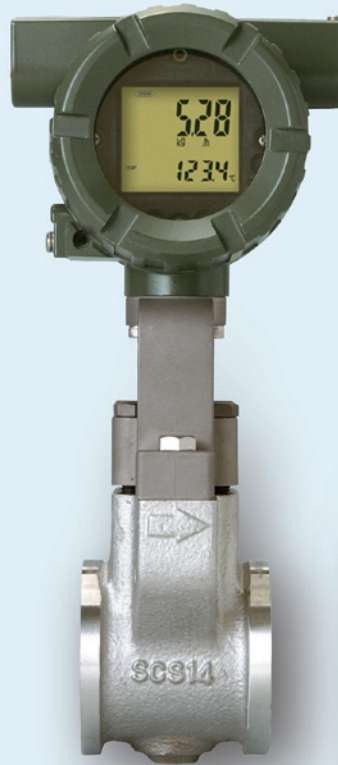
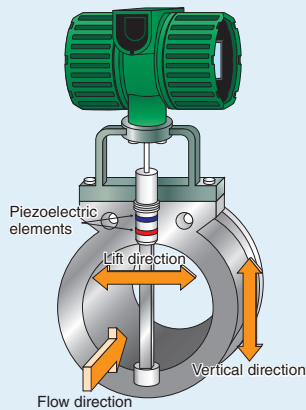

WAFER TYPE

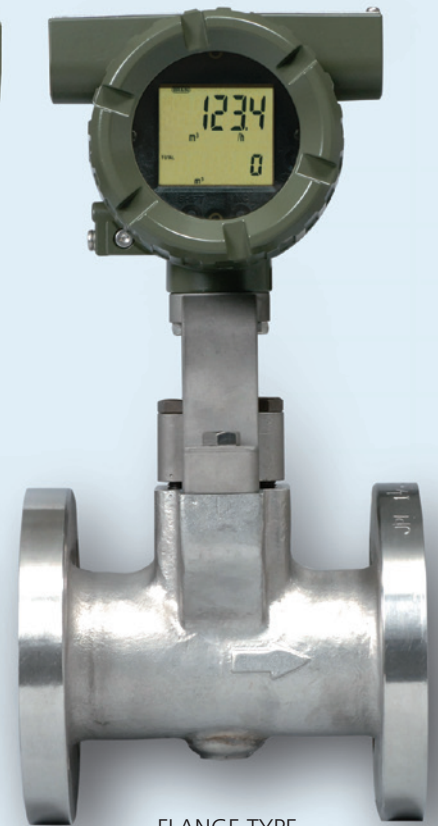

FLANGE TYPE

digitalYEWFLOW's SSP function provides enhanced vibration immunity and advanced diagnostics.

In the past some situations required manual adjustment to compensate for piping vibration noise.

digitalYEWFLOW is a maintenance-free flowmeter. It has a circuit for analyzing the detected frequency and allows only vortex frequency to pass through the segmented band-pass-filter, thereby accurately identifying and eliminating noise. The Spectral Signal Processing (SSP) function of digitalYEWFLOW only outputs the appropriate vortex frequencies, even under fluctuating flow rate conditions.

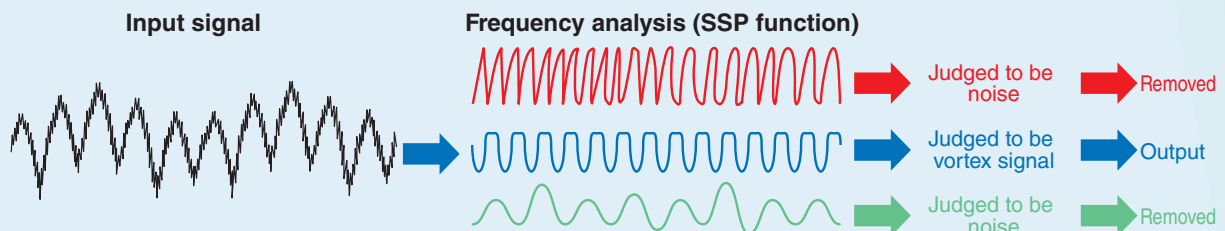

Lower Cost of Ownership

- Enhanced vibration immunity! No adjustment costs!
- Maintenance free! The self-diagnostic function reduces regular maintenance costs.
- User-friendly! Parameters are easily set by categorizing frequently used parameters into one group, reducing total maintenance costs!

Reduced Bore Type

Minimum measurable flow up to five times lower than conventional vortex flowmeter.

Integrated construction with reducers built into the flowmeter body.

Integrated construction allows for bore size reduction of up to 2 sizes.

- Enhanced safety achieved by integrated construction; No leak points!
- Same face-to-face dimension as the Standard Type makes replacement easier.

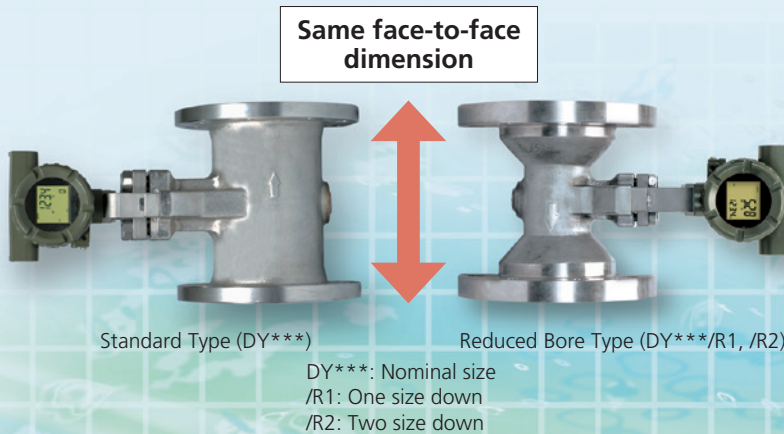
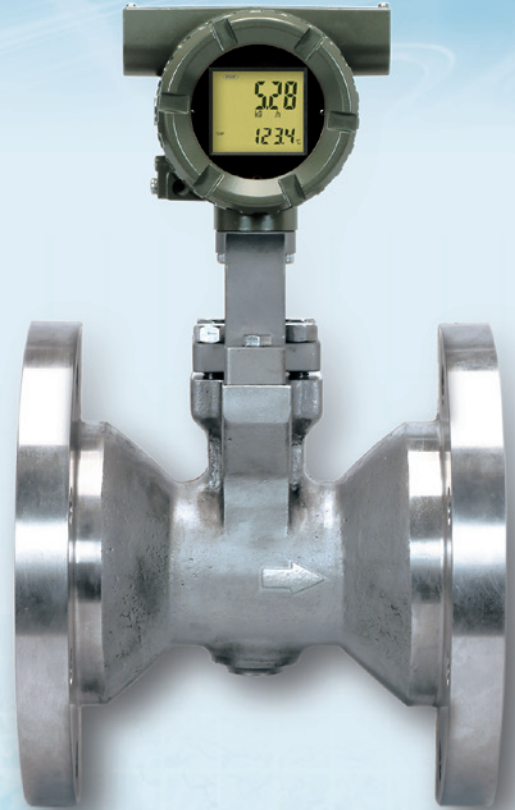

Measurable flow rate range (Sat.Steam, Ope.Pressure 500 kPa, Pipe size 50 mm)

<p>Reduced Bore Type R2 DY050/R2 (Detector size: 25 mm) Measurable range: 22 to 475 kg/h Suitable for LOW FLOWRATE</p>	<p>Reduced Bore Type R1 DY050/R1 (Detector size: 40 mm) Measurable range: 44 to 1132 kg/h Suitable for LOW FLOWRATE and WIDE RANGE</p>	<p>Standard Type DY050 (Detector size: 50 mm) Measurable range: 74 to 1876 kg/h Suitable for WIDER RANGE</p>
--	--	--



Lower Cost of Ownership

- No need for reducers/expanders or short pipes to achieve the required straight pipe length! Improves safety and reduces installation costs!
- Increases the space for installation of additional instrumentation.
- Improved stability in measuring low flow ranges! A single unit can perform such measurements, thereby reducing instrumentation costs.

New instrumentation using Reduced Bore Type

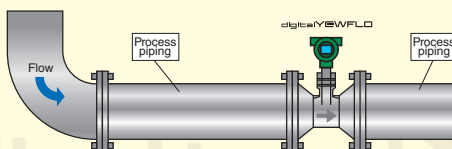

Traditional instrumentation

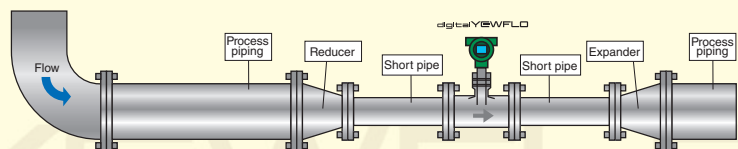

Multi-variable Type

The world's first two-wire Multi-variable vortex flowmeter (with built-in temperature sensor) can directly output the mass flow rate of saturated steam.

Shedder bar with built-in temperature sensor has a temperature monitoring function and a mass flow rate calculation function.

- Shedder bar with built-in temperature sensor: The shedder bar, which is strong enough to be used as a thermo-well, incorporates a RTD sensor (equivalent to Pt1000, Class A) for temperature measurement.
- SSP function facilitates highly accurate measurement of flow rate over a wide range, even under radically fluctuating temperatures.
- A combination of the reduced bore and multi-variable types is ideal for saturated steam instrumentation when the flow rate fluctuates largely.

Temperature Sensor

Built-in temperature sensor housed inside the shedder bar. Based on signals from the temperature sensor, which is protected by the shedder bar serving as a protector tube, the mass flow rate of saturated steam is calculated.

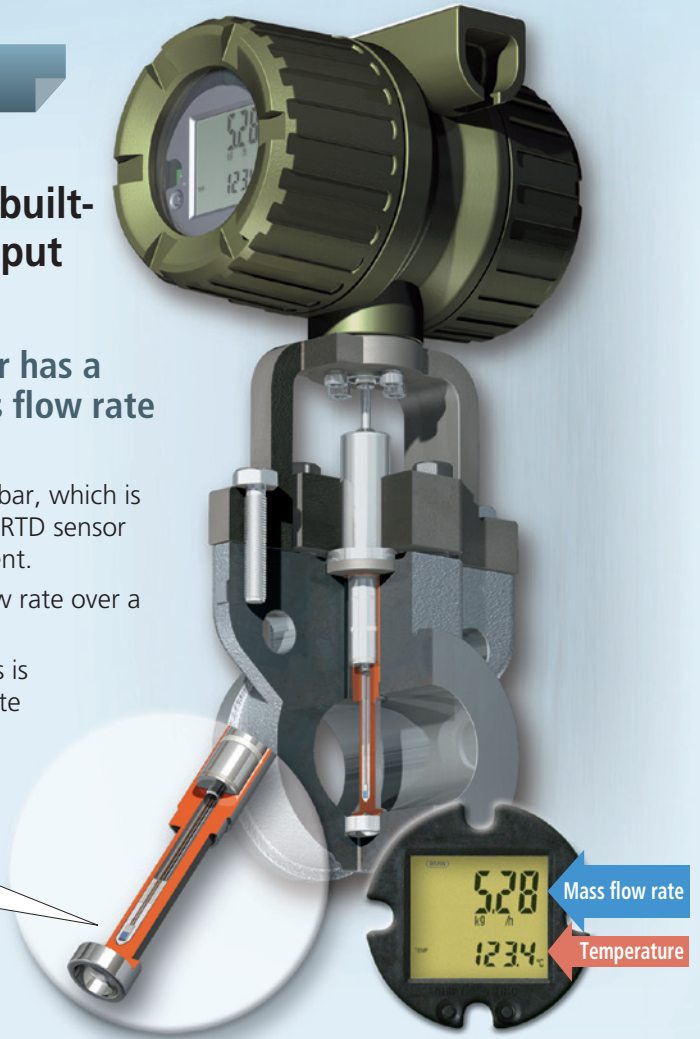

Temperature monitoring function

Readings of flow rate and temperature measurements are displayed simultaneously.

- ◆ Volumetric flow rate or mass flow rate (Pulse output) ⇒ Totalized value
- ◆ Temperature value (analog) ⇒ Process temperature value control

Mass flow rate calculation function

The saturated steam curve based on temperature measurement is used to directly output mass flow! Foundation Fieldbus Communication type can measure natural gas based on AGA No.8, general gas and liquid based on DIPPR physical database.

- ◆ A single digital YEWFLOW unit can perform highly accurate measurement of saturated steam.
- ◆ The ultimate solution for energy-efficient steam control
- ◆ Robust body and shedder bar construction for safer measurement and control
- ◆ The SSP function facilitates highly accurate measurement even when the boiler is vibrating.
- ◆ AR function block of Foundation Fieldbus Communication type configured by FSA120 FieldMate FlowNavigator realizes high accurate flow measurement of natural gas, general gas and liquid by using built-in temperature sensor or external temperature sensor and pressure sensor.

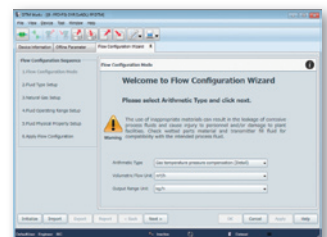

FlowNavigator™



Lower Cost of Ownership

- ➔ A high level of safety is assured without the expense or installation of a temperature sensor, and additional process connection is not required.
- ➔ Neither an external output temperature display unit nor a square root extractor is needed.

New saturated steam instrumentation of Multi-variable Type

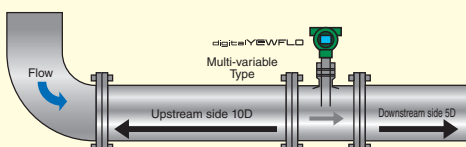

Traditional saturated steam instrumentation of T/P COMP.

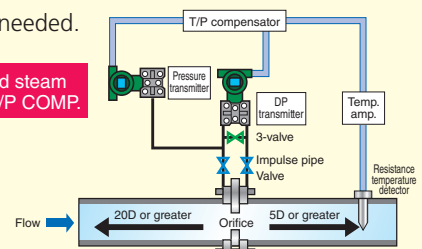

High Process Temperature Version / Cryogenic Version

For high temperature or cryogenic flow measurement.

Measurable temperature range:
Maximum +450°C, Minimum -196°C

- Easy installation and high level of safety with minimum fugitive emission points.
- Same face-to-face dimension as the Standard Type
- Simple construction for easy insulation work
- Available with Reduced Bore Type

Available size : High process temperature version: 25 mm to 400 mm
Cryogenic version: 15 mm to 100 mm

Stainless steel housing

Design

Converter housing, case and cover material is stainless steel which is durable for seawater damage.

Case and cover material: JIS SCS14A, ASTM CF8M stainless steel castings

Available size : 15 mm to 400 mm Remote type detector and Remote type converter



Beyond Standard Yokogawa's answer to your process needs.



■ ANSI Class 1500 Flange type

Design

Robust body with ANSI Class 1500 flange is ideal for high-pressure flow measurement.

Body material: ASTM F316, JIS SUS F316 or JIS SUS 316

Available Size : 25 mm to 200 mm

■ Dual-sensor type

Design

Constructed two welded vortex flowmeters (two sensors and two converters) output redundant signals.

Available model : Consult to our sales office.



■ Butt-welded type

Design

Direct welding type.

Available model :

Consult to our sales office.



digital YEWFLOW

■ Specification

	Standard	Reduced Bore	Multi-Variable
Model	digitalYEWFLOW Series Vortex Flowmeter (Integral type, Remote type detector, Remote type converter) (Option: High Temp. ver. /HT, Cryogenic ver. /LT)	(Option: Reduced Bore Type /R1, /R2) (Option: High Temp. ver. /HT)	(Option: Multi-Variable Type /MV)
Fluid to be measured	Liquid, Gas, Steam (Avoid multiphase flow and sticky fluids.)		
Nominal size	15 mm to 400 mm	R1: 25 mm to 200 mm, R2: 40 mm to 200 mm	25 mm to 200 mm (250 mm, 300 mm: Special)
Accuracy	Liquid: $\pm 1.0\%$ of reading ($20000 \leq Re \leq Dx10^3$) Liquid: $\pm 0.75\%$ of reading ($Dx10^3 \leq Re$)	Liquid: $\pm 1.0\%$ of reading ($20000 \leq Re$)	Liquid: $\pm 1.0\%$ of reading ($20000 \leq Re \leq Dx10^3$) Liquid: $\pm 0.75\%$ of reading ($Dx10^3 \leq Re$)
	Gas, Steam: $\pm 1.0\%$ of reading (Flow velocity less than 35 m/s) Gas, Steam: $\pm 1.5\%$ of reading (Flow velocity 35 m/s to 80 m/s)		
Output signal	Dual Output (both analog and pulse output can be obtained simultaneously.) Analog Output: 4-20 mA DC, 2-wire system Transistor Contact Output: Open collector, 3-wire system Pulse, Alarm, Status output are selectable. Contact rating: 30 V DC, 120 mA DC Low level: 0 to 2 V DC	Indication: Upper: FLOWRATE(%), FLOWRATE, *TEMPERATURE(%) Lower: BLANK, TOTAL, *TEMPERATURE *Options available for Multi-variable Type only Communication: HART 5/7; BRAIN; FOUNDATION Fieldbus	
Process temperature range	-29°C to +250°C (Standard) -196°C to +100°C (option: Cryogenic version) -29°C to +450°C (option: High Process Temperature version)	-29°C to +250°C -29°C to +450°C (option: High Process Temperature version)	-29°C to +250°C -29°C to +400°C (option: High Process Temperature version)
Process pressure limit	-0.1 MPa to flange rating.		
Ambient temperature	-29°C to +80°C (Integral type with Indicator) -29°C to +85°C (Integral type without Indicator)	-29°C to +85°C (Remote type detector) -30°C to +80°C (Remote type converter with Indicator) -40°C to +85°C (Remote type converter without Indicator)	
Ambient humidity	5 to 100%RH (Non condensing)		
Mounting	Flange or wafer type JIS10/20/40K, ANSI150/300/600/900 (1500: Special), DIN PN10/16/25/40/60/100/160	Flange type only JIS10/20K, ANSI 150/300	Flange or wafer type JIS10/20/40K, ANSI150/300/600/900, DIN PN10/16/25/40
Electrical connection	JIS G1/2 Female, ANSI 1/2NPT Female, ISO M20x1.5 Female		
Explosion protected type	TIS Ex d, FM Ex d, Ex ia, ATEX Ex d, Ex ia, Ex ic, CSA Ex d, Ex ia, IECEx Ex d, Ex ia		
Material	Body: Stainless steel. Nickel Alloy and Carbon steel by request Shedder bar: Duplex stainless steel, stainless steel, Nickel Alloy (option) Gasket: Stainless steel with polytetrafluoroethylene (Teflon) coating Converter housing, case and cover: Aluminum alloy, stainless steel (option)		

vigilantplant.[®]

The clear path to operational excellence

SEE
CLEARLY

KNOW
IN ADVANCE

ACT
WITH AGILITY

VigilantPlant is Yokogawa's automation concept for safe, reliable, and profitable plant operations. VigilantPlant aims to enable an ongoing state of Operational Excellence where plant personnel are watchful and attentive, well-informed, and ready to take actions that optimize plant and business performance.

YOKOGAWA ELECTRIC CORPORATION

World Headquarters

9-32, Nakacho 2-chome, Musashino-shi, Tokyo 180-8750, Japan
<http://www.yokogawa.com/>

YOKOGAWA CORPORATION OF AMERICA

2 Dart Road, Newnan, Georgia 30265, U.S.A.
<http://www.yokogawa.com/us/>

YOKOGAWA EUROPE B.V.

Euroweg 2, 3825 HD Amersfoort, The Netherlands
<http://www.yokogawa.com/eu/>

YOKOGAWA ENGINEERING ASIA PTE. LTD.

5 Bedok South Road, Singapore 469270, Singapore
<http://www.yokogawa.com/sg/>

YOKOGAWA CHINA CO., LTD.

3F Tower D, Cartelo Crocodile Building,
No.568 West Tianshan Road, Shanghai 200335, China
<http://www.yokogawa.com/cn/>

YOKOGAWA MIDDLE EAST & AFRICA B.S.C.(c)

P.O. Box 10070, Manama Building 577,
Road 2516, Busaiteen 225, Muharraq, Bahrain
<http://www.yokogawa.com/bh/>

Represented by:

F-L-03E

Printed in Japan, 510(KP) [Ed : 04/b]