

# LAND

## Slag Detection System

Continuous Thermal Monitoring to  
Minimise Slag Carry-Over in Steel  
Production

An **AMETEK**® Company

**When liquid steel is tapped from a basic oxygen or electric arc furnace, it is essential to minimise the quantity of slag carried over into the ladle.**

## The Problem

---

- Slag layer hinders addition of alloys and conditioners
- High levels of FeO and MnO results in high oxygen content of steel, leading to increased processing time and treatment costs
- High inclusion formation, steel cleanliness problems and increased risk of nozzle clogging in the caster
- Phosphorous reversion in the ladle
- Poor ladle desulphurization
- Ladle refractory wear

## The Solution

---

The Slag Detection System (SDS-E) has been developed using Land's expert knowledge of the application and over 60 years experience in the steel industry to monitor and aid control of slag carry-over from one process to another.

### Rugged Design

The SDS-E system is specially designed to withstand the harsh conditions of continuous operation in the steel plant, with minimum maintenance required. The industrial thermal imaging sensor is housed in a rugged water-cooled and air purged enclosure, continuously viewing the tapping area. As the tap commences, the dedicated LIPS SDS-E software automatically records the tap using stream identification and produces a data log and graph of the relevant steel/slag data.

### Intelligent Imaging

When the level of the slag reaches the predetermined level an alarm is generated to stop the tap. The recording will end and the files saved by tap number. Full access of the tapping data is available for quality control purposes.

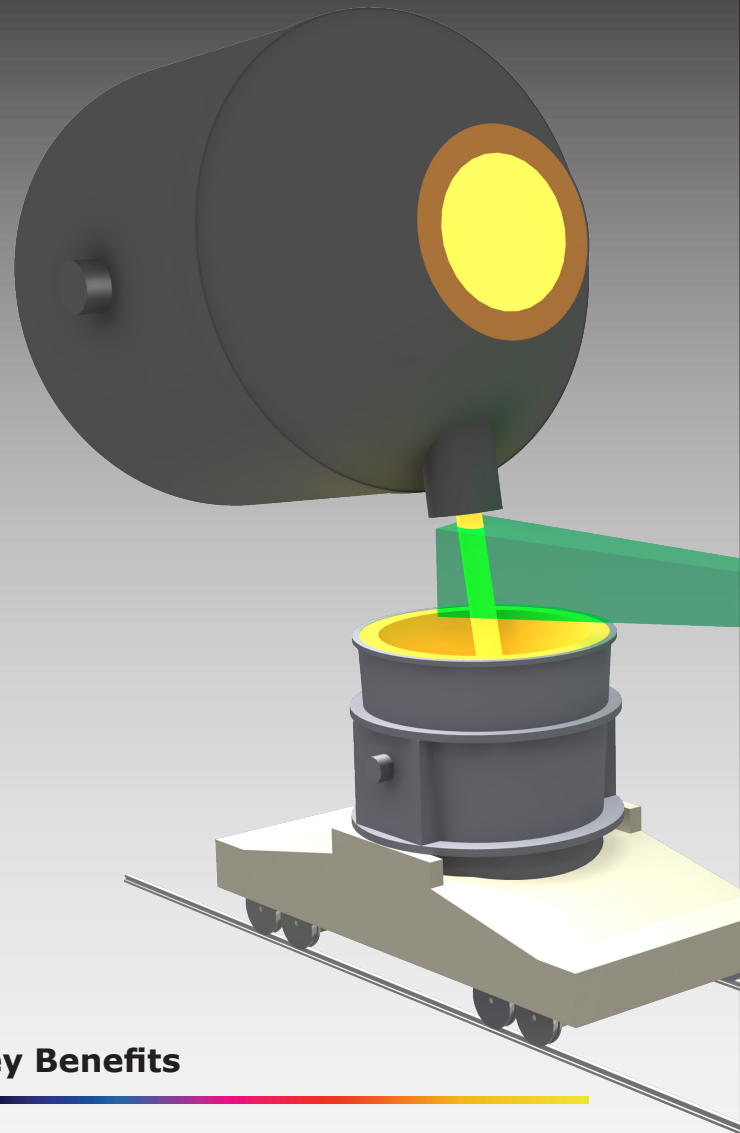

## Key Benefits

---

- Improved production yield
- Lower slag content improving steel quality
- Lower maintenance on BOF/ EAF vessel
- Reduced energy costs

## Key Features

---

- Automatic stream identification and tracking - accurately identifies the stream and reduces background interference
- Alarms generated by the system directly stop the tap before the slag is carried over
- Fully automatic operation
- Accurate detection independent of charge weight
- Reliable alarm independent of the operator
- Improved connectivity through the use of Ethernet

**"Automatic stream identification and tracking - accurately identifies the stream and reduces background interference"**

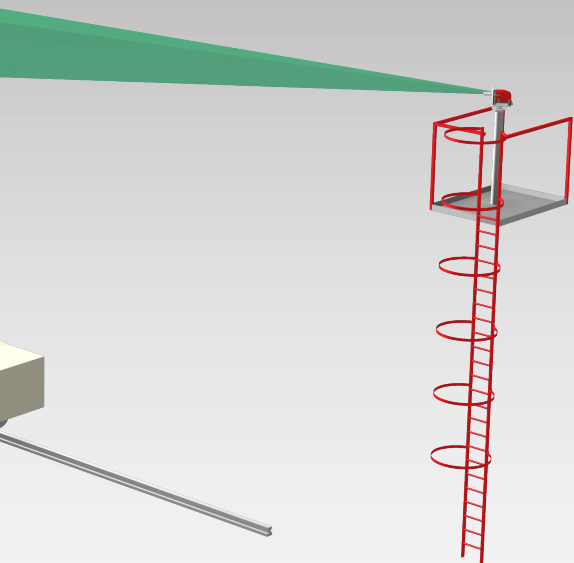

## Automatic Stream Tracking

Another new feature of the SDS-E System is automatic stream tracking. The dedicated LIPS SDS-E software has the option to track the width and position of the stream regardless of the position of the sensor unit.

When viewing the stream from an acute angle, its position will change during the different phases of the tap - the LIPS SDS-E software accurately tracks any movement that may occur as the pour takes place, only measuring from the area identified as the stream. This reduces any errors caused by background heat sources in the field of view.

## Fibre-Optic Connectivity

The SDS-E Power Supply unit is supplied with fibre-optic 100Base-FX Fast Ethernet connectivity for easy installation and integration into existing plant systems.



*The Slag Detection System has a robust housing assembly, which views directly the liquid metal stream as the steel is tapped.*

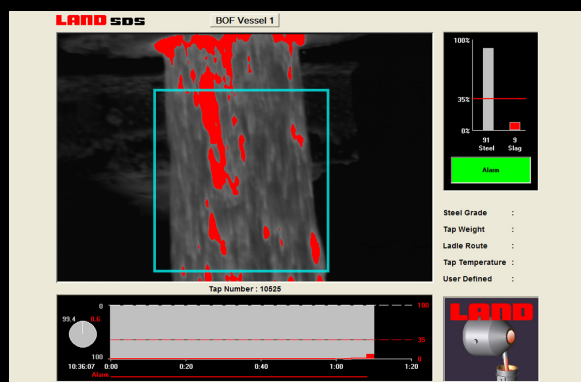

*The SDS-E display allows users to observe critical tap information such as the live thermal image, steel and slag percentages, time versus percentage graph, alarm level and alarm status.*



*Robust SDS-E protection enclosure, with sacrificial protection plate and durable sapphire window*

# LAND

# Powerful Detection System Prevents Slag Carry-over

This comprehensive, fully featured software system has been developed to provide the steel plant engineers and managers with the tools to develop and improve the transfer of steel from one process to another.

SDS-E offers the steel plant a number of inter-connectivity methods for on-line control and, more importantly, it automatically records the tap data in three forms for post analysis and future process improvement.

In addition to this, the image processing system has been pre-installed and configured to work straight out of the box – minimum set-up is required. Once the system hardware is installed onto the steel plant, the moment the system is turned on, the steel plant can immediately begin to reduce slag carryover. No other thermal slag detection system currently available offers these features.

## Observe Critical Tap Information

Pre-installed on the powerful image processing system, the display allows users to observe critical tap information such as the live thermal image, steel and slag percentages, time versus percentage graph, alarm level and alarm status.

Secondary information such as tap number, sensor temperature, communications status, tap duration, steel / slag ratio and record status are less prominent so as to not distract the user during the tap.

## View the Tap Information Throughout the Plant

Up to four users can also view remotely a condensed view of the live tap anywhere on the plant network by using the remote viewer software.

At the end of the tap the video, text data and graph are saved by tap number for later analysis and can be automatically deleted after a user defined number of days.

Inputs and outputs from the steel plant and slag detection system include: digital and analogue outputs, Ethernet and OPC.

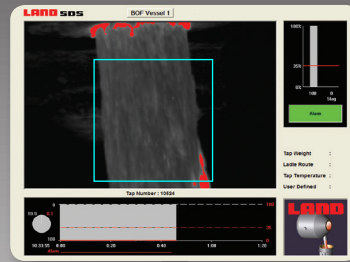

### How Slag carry-over is prevented

The following sequence of screens clearly illustrates how the SDS-E tracks the onset of slag, finally activating an alarm to stop the tapping process, preventing slag carry-over.

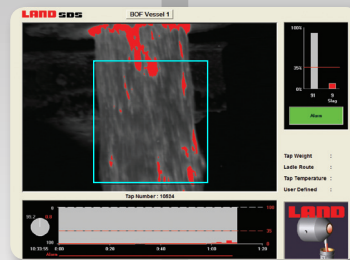

### Screen 2

The Alarm is still showing green. Steel is at 91% (slag at 9%)

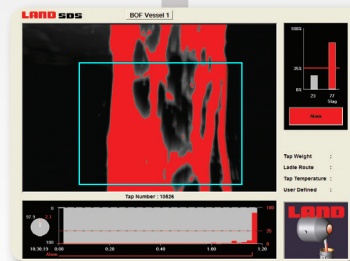

### Screen 3

The Alarm is now showing red. The Steel content has fallen to 23% (slag at 77%). The alarm level (set at 35 % slag) was triggered, the tap is then stopped.

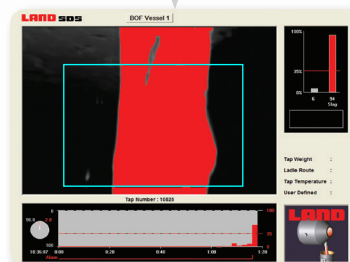

### Screen 4

The SDS-E continues monitoring after the alarm has been triggered, showing the slag content rising to a maximum of 94%.

## Straightforward Connectivity

Connecting the image processing system to the plant network via either OPC or Ethernet protocols allows live data transfer to and from the slag detection system to improve the steel transfer process.

Data to the slag detection system includes tap number, alarm level and five unique variables specified by the steel plant such as charge-number, heat-number, steel grade and tap temperature. When used, these data are recorded in the saved text data file.

Data output from the system can be transmitted at the equivalent of 30 frames per second.

This information includes steel slag percentage, alarm status, sensor temp and communications status.

## Full Screen Display (shown)

Allows users to observe the critical live tap information.

The three main display screens show the live thermal image, alarm level window and display graphs.

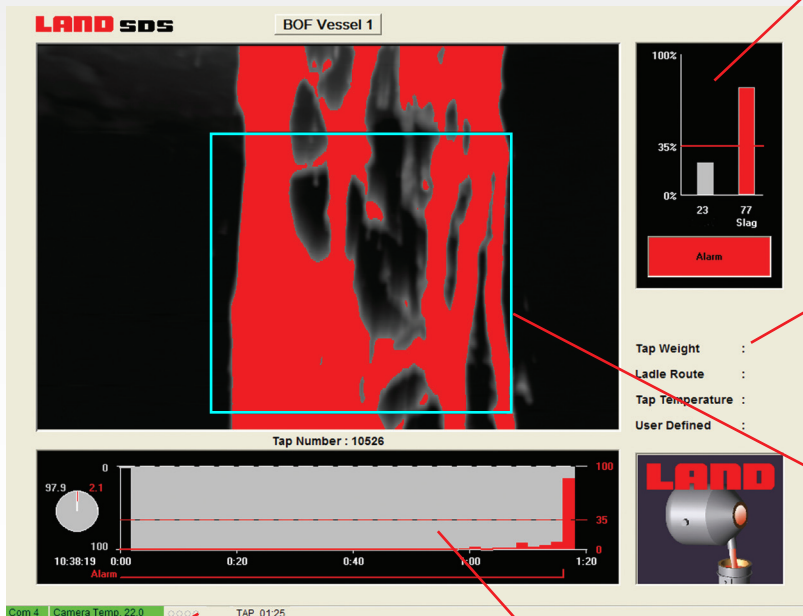

### System Status Bar

Displaying communication status, imager temperature status, tap duration and Ethernet connections.

### Display Graphs

A bar or line graph displays the steel and slag percentage versus time. A pie chart illustrates the total steel slag pixels during each tap, this is extremely useful when comparing taps. This screen also shows alarm condition status.

This information, along with the thermal video and all text data, is automatically recorded as soon as the tap commences.

## Remote Viewer

Up to 4 remote connections allow viewing of live tap information to be viewed anywhere on the plant network.

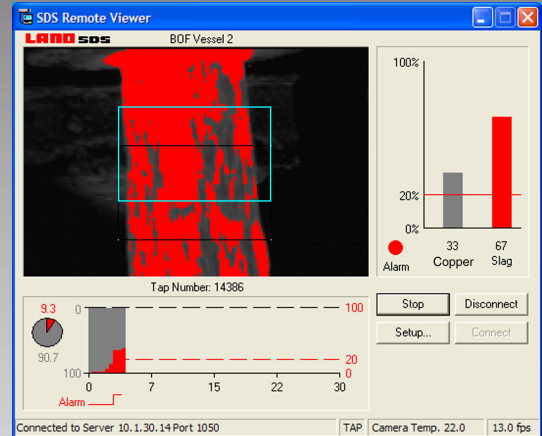

## Language

When operating in Full Screen mode, the software offers local language support.

### Alarm Level Window

- Steel and slag percentages
- Alarm level
- Alarm status
- Steel, slag alarm percentage, steel/slag alarm status, available via OPC and Ethernet connection. Values can be transferred to the SDS-E from the steel plant via OPC or Ethernet.

### User Defined Variables

Any five user defined variables can be chosen with corresponding values as determined by the steel plant.

This information is included in the auto record data for each tap.

### Automatic Stream Tracking

Automatically identifies and tracks the stream position within the thermal scene to reduce the effect of background interference.

## Protective Enclosure dimensions

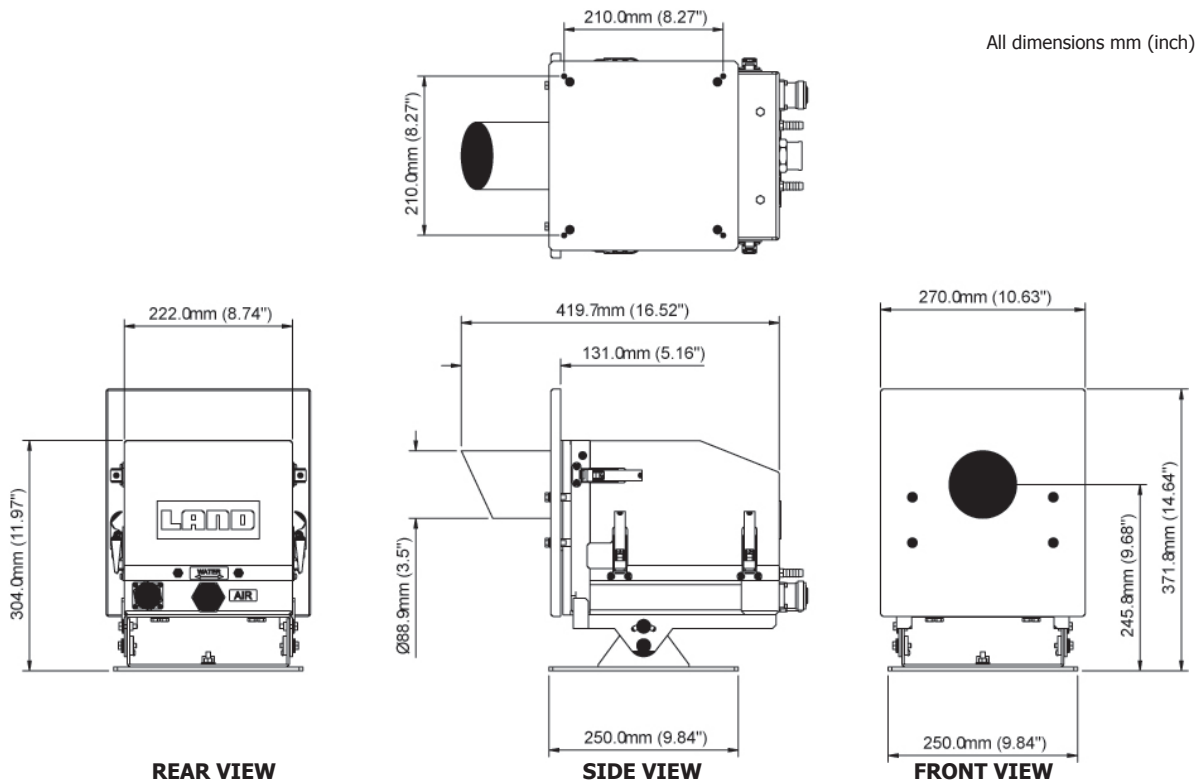

## Sensor Supply Unit dimensions

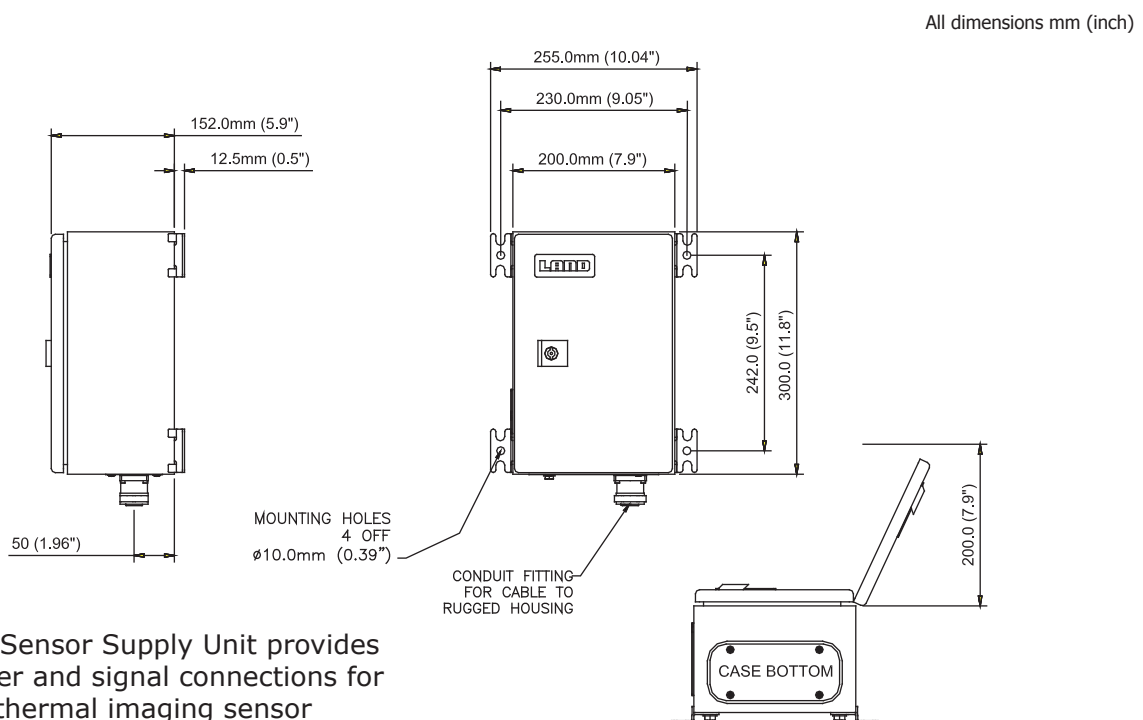

The Sensor Supply Unit provides power and signal connections for the thermal imaging sensor

## Outline Specifications

<b>Image Processing System (LIPS SDS-E)</b>	
Slag Detection	Alarm activation when a preset percentage of either slag or steel detected within defined window
User Display	Front page information display, plant logo and location identifier
Frame Rate	30 frames/sec
Automatic Functions	Auto tap detection, stream identification, steel/slag ratio, video file, log file of all data, steel/slag percentage graph, all saved as tap number.
Language	User defined
Outputs	Digital output card, DDE, OLE, Ethernet and OPC Options
<b>Sensor Supply Unit</b>	
Functions	Local connection interface between imaging sensor and image processing system
Cables	30/150/300 m pre-wired and labelled, greater distances to 1 km are available
<b>Protective Enclosure</b>	
Service	Water, air, power input, communications, video, located to the rear of the enclosure
Added Protection	Sacrificial plate protects the main enclosure from direct impact
Sighting Tube	Design significantly reduces the risk of direct impact of liquid steel against the field replaceable sapphire window
Air Bleed	Provides positive pressure within the enclosure
Environmental Rating	IP65
<b>Thermal Imaging Sensor (SDS-E)</b>	
Temperature Measurement Range	600 to 2000°C / 1472 to 3632°F
Thermal Image Resolution	384 x 288 pixels
Detector	Amorphous Silicon Focal Plane Array
Field of View	7.5° (horizontal) x 5.5° (vertical)
Motorised Focussing Range	4m / 13.1 ft to infinity
Temperature Resolution	0.5°C (for 600°C blackbody)
Accuracy	±1% absolute temperature (K)
<b>Options</b>	
	Air Purge, Blower unit, Setup Monitor, Sensor Carry Case

## Typical System

- Pre-configured image processing system
- Fibre-optic connectivity
- Power unit mounted up to 10m / 30ft from the sensor enclosure
- Rugged water-cooled enclosure with an integral air purge and adjustable bracket
- High-resolution FPA thermal imaging sensor and integrated telephoto lens
- Optional air purge blower unit and hose mounted up to 30m / 100ft from the sensor enclosure

## Other Process Imaging Application in the Steel Industry

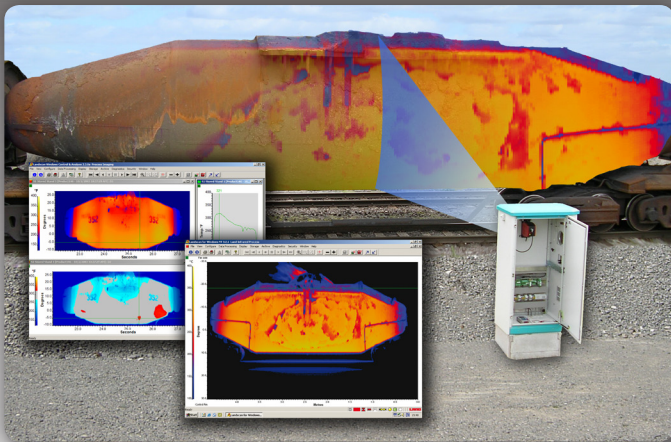

The **LAND Torpedo Car Temperature Profiling System** uses a Landsan Infrared Linescanner to produce highly detailed thermal profiles of each side of the torpedo car. The close measurement distance enables the system to view very small surface details, easily identifying the development of hotspots

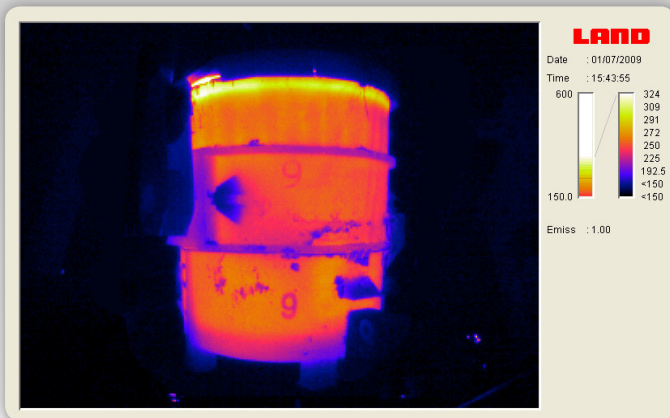

The maintenance of the refractory linings of furnaces and ladles is a significant contribution to the cost of the production of steel. Monitoring the external temperature pattern of ladles allows the extent and distribution of wear to be assessed. This information can be used to determine relining strategy in order to maximise the availability of the ladles and avoid excessive lining damage and break-outs.

The **LAND Ladle Refractory Monitoring System** is an integrated solution meeting the temperature measurement requirements of steel plants across the world.

## Intelligent Imaging

Intelligent Imaging solutions aim to solve problems by providing more than just a measurement. Land is able to provide a custom solution according to your requirements; this includes custom temperature ranges, application specific mountings, and bespoke communications protocols.

# LAND

Land Instruments International Ltd • Dronfield S18 1DJ • England  
 Email: [land.infrared@ametek.co.uk](mailto:land.infrared@ametek.co.uk) • [www.landinst.com](http://www.landinst.com) • Tel: +44 (0) 1246 417691 • Fax: +44 (0) 1246 410585

AMETEK Land, Inc. • 150 Freeport Rd • Pittsburgh, PA 15238 • U.S.A.  
 Email: [irsales@ametek.com](mailto:irsales@ametek.com) • [www.ametek-land.com](http://www.ametek-land.com) • Tel: +1 (412) 826 4444 • Fax: +1 (412) 826 4460

For a full list of international offices, please visit [www.landinst.com](http://www.landinst.com)

**Non-Contact Temperature  
 Measurement Solutions**



An **AMETEK**® Company

Applies in the UK

Applies in the USA