

General Specifications

TB820D, FLXA402T Right Angle Scattered Light Turbidity Analyzer

GS 12E01B30-01EN

■ General

To keep good quality in industrial or drinking water and rivers or streams, "Turbidity" is one of the important measurement parameters to control water quality.

Turbidity analyzer is more than ever demanded not only for water treatment, but currently for measurement/detection of suspended substances in industrial waste or of turbidity at chemical processing facility.

Since their sales began in 1959, Yokogawa turbidimeters have been continuously developed and improved using various measurement principles suited for various applications. With its many achievements, Yokogawa has earned its customers' confidence.

Right Angle Scattered Light Turbidity Analyzer, composed of Turbidity Detector TB820D and Liquid Analyzer FLXA402T, is a next-generation analyzer, developed based on years of experience, combining the reliable measurement principle with our latest digital sensor technology realizing high efficiency in facility operations.

FLXA402T is a converter designed, being tailored from the well-received FLXA402, to provide multiple detector measurement. In addition to conventional analog output, Modbus TCP, Modbus RTU/RS485 are available.

The technology of predictive maintenance prevents accidental shutdown of the factory and reduces OPEX. TB820D has drastically improved maintainability and minimized the maintenance time.



■ Features

TB820D

- Reliable right angle scattered light method
- Long life of 3 years by LED light source.
- High sensitivity, High precision
 - Realized good linearity, repeatability
 - Display resolution: 0.001 NTU
- Measuring range: 0-0.2 NTU to 0-500/700 NTU
- Adopt wide range measurement conditions;
Low flow rate (0.05 to 20 L/min), High pressure (500 kPa or less), Sample temperature (0 to 50°C)
- Improved wash system for less maintenance
 - No need to adjust optical axis, reducing maintenance time down to 1/3 of conventional meter
 - Easy cleaning cell structure
 - Contamination-resistant, long-stability variable cleaning options: Ultrasonic cleaning, Automatic flash cleaning, Automatic Zero calibration

FLXA402T

- Active diagnosis advice service
 - Condition of light source, driness level of detector
 - Input element failure, calibration failure, various circuit failures, etc.
- Multiple detector/sensor connection
 - Turbidity, Free-available chlorine, pH, Conductivity
- Analog outputs, Digital communications (Modbus RTU or Modbus TCP/IP)
- Multilingual display
 - English, German, French, Chinese, Korean, Spanish, Portuguese, Japanese
- Automatic analog output range switching (2 or 3 range changing)

FLEXA, FLXA, SENCOM are trademarks or registered trademarks of Yokogawa Electric Corporation.
All other company and product names mentioned in this document are trademarks or registered trademarks of their respective companies.
We do not use TM or ® mark to indicate those trademarks or registered trademarks in this document.

■ System Configuration (multiple connection)

FLXA402T enables multiple sensor/detector connection for chlorine (Non-reagent type), turbidity, pH, conductivity. Select 2nd Input for pH or conductivity parameter.

To connect FLXA402T to both a chlorine sensor and a turbidity detector, select -CL (FC800D-□□-A□-NN-NN) to the 1st Input.

Invalid combination:

“-TB” (SENCOM SA for Turbidity) on 1st Input and “-CL” (SENCOM SA for Chlorine) on 2nd Input.

To connect FLXA402T to both a chlorine sensor and a turbidity detector, read the general specification [GS 12F05B10-01EN](#) for FC800D-FLXA402T.

Select -TB (TB820D-□□-A□-□□-□□-CT-NN) to 1st Input.

2nd Input	-TB	-P1	-C1
Connectable sensor/detector (to be purchased separately)	TB820D	FU20, FU24, SM21/SR20 PH20 SC25V SC21 SC29C PH8E□P PH4□ PH4□□	SC4A SC42 SX42 SC4AJ SC8SG SC210G
Conditions	TB820D-□□-A□-□□-□□-CT-NN	Except for Variopin connector (-V) of PH8E□P	Except for Variopin connector (-VS) of SC4AJ, SC8SG. Except for Variopin connector (-□V) of SC42, SX42.

FLXA402T 2nd input “-TB”

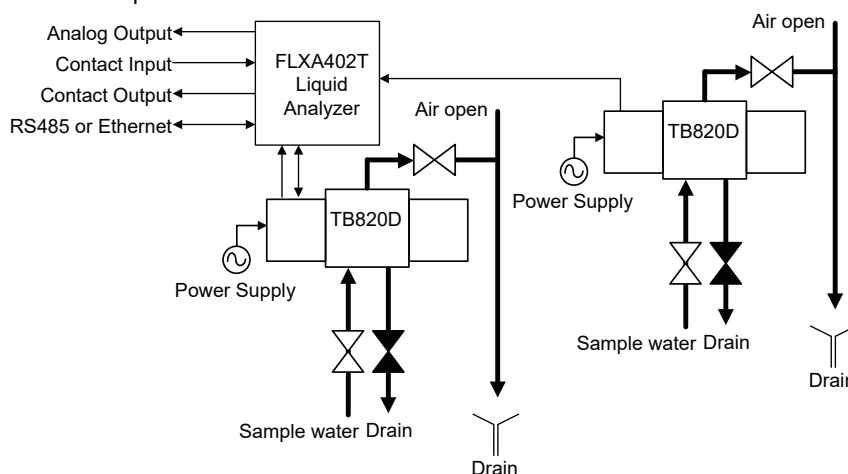

FLXA402T 2nd input “-P1” or “-C1”

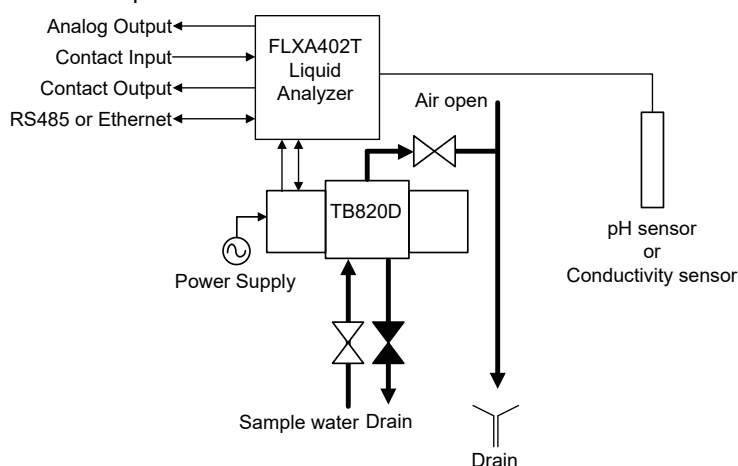

■ General Specifications

1. TB820D Right Angle Scattered Light Turbidity Detector

■ Measurement

Turbidity of water in water purification plant, river water and water used in factory processes.

■ Detector

Light source: Red Light LED (660 nm),
Infrared light LED (860 nm ISO 7027)
Measuring method: Right angle light scattering method
Measuring: 0-0.2 to 0-500 NTU (Light source 660 nm)
0-0.2 to 0-700 FNU/NTU (Light source 860 nm)

Turbidity unit: NTU, FNU, FTU, TU, mg/L,
user defined, selected on FLXA402T

Turbidity standard: Formazin

Linearity:

0-40 NTU : $\pm 2\%$ of reading or ± 0.01 NTU
whichever is greater
over 40NTU to 100NTU: $\pm 5\%$ of reading
over 100NTU: $\pm 10\%$ of reading

Repeatability:

0-100 NTU range: $\pm 1\%$ of reading or ± 0.002 NTU
whichever is greater
over 100 NTU : $\pm 2\%$ of reading
when Check tool is used

Response time: Within 2 minutes

(90% response, sample flow rate 3 L/min)

Sample conditions:

Flow rate: 0.05 to 20 L/min

Temperature: 0 to 50°C

Pressure: 500kPa max

Zero Calibration water and Cleaning water conditions

Turbidity: 2 mg/L or less

Temperature: 0 to 50°C

Pressure; 100 to 500 kPa

Water Consumption:

Zero Calibration; Approx. 25 L/day

(In case of 3L/min flow rate)

■ Electrical

AC Power Supply

Ratings: 100 to 240 V AC

Acceptable range; 90 to 264 V AC

Ratings: 50/60 Hz

Acceptable range: 50 Hz $\pm 5\%$, 60 Hz $\pm 5\%$

Power consumption: 15VA

Communication signal:

RS485 (Modbus RTU) 9600bps

The maximum cable length between Analyzer and

Detector is 20 m

■ Mechanical and others

Case: m-PPE resin

(Wetted parts: m-PPE, Resin, Glass, Fluororubber (FKM), Silicon rubber, EPDM, SUS316, PVC (Rigid polyvinyl chloride), PP, PMMA)

Finish; none

Color: Black

Protection: IP65, Type4X

*In case of using outside and under sunlight, please put an analyzer under a roof.

Weight: max: 4.9 kg

Mounting:

Wall mounting (standard)

Pipe mounting (option)

Terminal screw size: M3 (Earth terminal: M4)

Cable gland:

6 hole, M20 cable gland x 6

(For 6 to 12 mm outer diameter cable)

Pipe connection:

Detector

Sample inlet/outlet; Rc1/2(standard) or 1/2NPT(option)

Drain port; Rc1/2 (standard) or 1/2 NPT(option)

Conduit adapter (option):

G1/2, 1/2NPT or M20 \times 1.5

Stainless steel tag plate (option)

In case you specified Option code /SCT, Tag plate which is printed numbers is shipped with product. You can attach this tag by wire.

Warm up time: Approx. 30 min

Installation/Storage environment:

Ambient Operating Temperature; -5 to 55°C

(Please keep water flowing and avoid frozen up.)

Storage Temperature; -30 to 70°C

Humidity; 10 to 90 % RH at 40°C

(No condensation)

Indoors (A separate rainproof cover is required for outdoor installation. Required a roof to avoid direct sunshine)

■ Option:

Head tank options:

Simple head tank:

Application: Turbidity is from 2 NTU to 10 NTU

To remove relatively large air bubbles.

Sample conditions:

Flow rate: 1 to 10 l/min

Pressurized head tank for low turbidity:

Application: Turbidity is 2 NTU or less.

To remove air bubbles and to prevent them from occurring.

Sample conditions:

Flow rate; 0.05 to 10 l/min

Turbidity; 2 NTU or less

Pressure; 20 to 500 kPa

Head tank:

Application: Turbidity is over 2 NTU

To remove air bubbles and some dirty

Sample water conditions: Flow rate: 1L to 10L

Cleaning option:

Ultrasonic cleaning (selected by suffix code);

PG400G Ultrasonic Oscillator should be purchased separately.

Zero turbidity filter:

When measuring range is 2.0 NTU or greater: 1 μ m

When measuring range is below 2.0 NTU: 1 μ m + 0.2 μ m

■ Safety standard, EMC and RoHS

Safety:

UL 61010-1, UL 61010-2-030

CAN/CSA-22.2 No.61010-1

CAN/CSA-C22.2 No.61010-2-030

EN 61010-1, EN 61010-2-030,

GB30439

Installation altitude: 2000 m or less

Overvoltage category (IEC 61010): II (*)

Pollution level (IEC 61010): 2 (**)

(*): Installation category, called over-voltage category, specifies impulse withstand voltage.

Equipment with Category II is energy-consuming equipment to be supplied from the fixed installation.

(**): Pollution level shows the level of existing the solid, liquid and gas which break electrical isolation.

Category 2 is applied to normal room environment

EMC:

EN 61326-1 Class A, Table 2 (For use in industrial locations)

EN61326-2-3

EN61000-3-2

EN IEC 61000-3-2

EN61000-3-3

RCM: EN 55011 Class A, Group 1

Korea Electromagnetic Conformity Standard

한국 전자파적합성 기준 Class A

Environmental regulation

RoHS: EN IEC 63000

Information of the WEEE Directive

This product is purposely designed to be used in a large scale fixed installations only and, therefore, is out of scope of the WEEE Directive. The WEEE Directive does not apply.

The WEEE Directive is only valid in the EU

2. FLXA402T Liquid Analyzer

FLXA402T Liquid Analyzer is a common converter for Chlorine sensor unit and Turbidity detector. In this GS, only function and specification are provided for the connection between FLXA402T and TB820D.

2-1 Measurement**■ SENCOM SA for Turbidity**

Unit: NTU, FNU, FTU, TU, mg/L You can input any letters by alphanumeric.

Display resolution: 0.000 to 9999

Regarding specification of detector, refer to 1.TB820D Right Angle Scattered Light Turbidity Detector

■ pH (PH)**When 2nd Input is -P1 (PH)****Input Specification**

Dual high impedance input ($\geq 10^{12} \Omega$)

Input Range

pH: -2 to 16 pH

Temperature:

Pt1000: -30 to 140 °C

Pt100: -30 to 140 °C

6k8: -30 to 140 °C

PTC10k: -30 to 140 °C

NTC 8k55: -10 to 120 °C

3k Balco: -30 to 140 °C

PTC500: -30 to 140 °C

Output Range

pH: min. span 1 pH

max. span 20 pH

Performance (Accuracy)

(The specifications are expressed with simulated inputs.)

pH

Linearity: ± 0.01 pH

Repeatability: ± 0.01 pH

Accuracy ± 0.01 pH

Temperature

with Pt1000, 6k8, PTC10k, NTC 8k55, 3k Balco, PTC500

Linearity: ± 0.3 °C

Repeatability: ± 0.1 °C

Accuracy: ± 0.3 °C

with Pt100

Linearity: ± 0.4 °C

Repeatability: ± 0.1 °C

Accuracy: ± 0.4 °C

Temperature compensation

Function:

Automatic or manual. Compensation to Nernst equation. Process compensation by configurable temperature coefficient. Manual adjustment with automatic stability check.

Calibration

Semi-automatic 1 or 2 point calibration using pre-configured NIST, US, DIN buffer tables 4, 7 & 9, with automatic stability check. Manual adjustment.

■ Conductivity (SC)**When 2nd Input is -C1 (SC)****Input Specification**

Two or four electrodes measurement with square wave excitation, using max 60m (200 ft) cable (WU40/WF10) and cell constants from 0.005 to 50.0 cm^{-1}

Input Range

Conductivity:

min.: 0 $\mu\text{S}/\text{cm}$

max.: 200 $\text{mS} \times (\text{Cell constant})$

(over range 2000 mS/cm)

Temperature:

Pt1000: -20 to 250 °C

Pt100: -20 to 200 °C

Ni100: -20 to 200 °C

NTC 8k55: -10 to 120 °C

Pb36(JIS NTC 6k): -20 to 120 °C

Output Range

Conductivity:

min. 0.01 $\mu\text{S}/\text{cm}$

max. 2000 mS/cm (max 90% zero suppression)

Temperature:

min. span 25 °C

max. span 270 °C

Performance (Accuracy)

(The specifications are expressed with simulated inputs.)

Conductivity

2 $\mu\text{S} \times \text{K} \text{cm}^{-1}$ to 200 $\text{mS} \times \text{K} \text{cm}^{-1}$

Accuracy: $\pm 0.5\%$ F.S.

1 $\mu\text{S} \times \text{K} \text{cm}^{-1}$ to 2 $\mu\text{S} \times \text{K} \text{cm}^{-1}$

Accuracy: $\pm 1\%$ F.S.

Temperature

with Pt1000, Pb36, Ni100

Accuracy: ± 0.3 °C

with Pt100, NTC 8k55

Accuracy: ± 0.4 °C

Temperature compensation

NaCl table: $\pm 1\%$

Step response: 90 % (< 2 decades) in 7 seconds

Note: "F.S." means maximum setting value of converter output.

"K" means cell constant.

YOKOGAWA provides conductivity sensors of which cell constants are 0.1 to 10 cm^{-1} .

2-2. Electrical**■ Display**

Display: QVGA color LCD with a touch screen

Message Language: English, German, French, Chinese, Korean, Spanish, Portuguese, Japanese

Note: You may find some image loss, uneven brightness, or afterimage on display. They are generated from the product features but not defects

■ AC Power supply;

Ratings: 100 to 240 V AC
 Acceptable range; 90 to 264 V AC
 Ratings: 50/60 Hz
 Acceptable range; 50 Hz \pm 5 %, 60 Hz \pm 5%
 Power Consumption: 35 VA

■ Output signal:

Isolated outputs: 4-20 mA DC
 Accuracy: \pm 0.02 mA
 Repeatability: \pm 0.02 mA
 Linearity: \pm 0.02 mA
 Maximum load: 600 Ω
 Number of outputs: select by suffix code
 2 isolated outputs: -N2
 4 isolated outputs: -N4

(Not isolated between analog outputs 1 and 2)

Output range: Configure within measurement range

Minimum range: minimum measurement range
 Maximum range: maximum measurement range

(*) In case auto range switching function is enable, low range is fixed by 0 mg/L.

Automatic range switching function:

Ch1: No switching or switching in 2 or 3 points
 You can select the followings.
 "Manual range switching, Remote range switching, Automatic 2ranges switching, Automatic 3ranges switching
 Ch2-Ch4: No switching or 2 range switching
 You can select the followings.
 "Manual switching, Remote 2 range switching"

Output function: Linear output or 3 points polyline output (Set upper/lower value and another one point. The values between them are filled by linear.)

Output current; 2.4 to 21.6 mA

Output signal during maintenance (HOLD): Enable/Disable keep output value function during setting, calibration and maintenance (Automatic hold function).

You can set HOLD value the last value or any value between 2.2 mA to 22.0 mA

Burn out function (NAMUR 43)

Analyzer can output 2.2 mA (Burn down) or to alarm failure.

Burn down: 2.2 mA

Burn up: 22.0 mA

■ Contact outputs

When -WR is selected.

Type: No-voltage contact output
 Number: 4 contacts (S1/S2/S3/S4)
 Contact S4 is for Fail-safe function.
 Function: Selectable 4 functions among Alarm, maintenance mode, wash/calibration status, mA1 output range status.

Identification of range switching:

Contacts (S1/S2/S3) identifies mA output range. Up to 3 contacts are used for 3 ranges. Refer to User's manual when using 2 contacts to identify 3 ranges.

Switch capacity:

Maximum values; 100 VA, 250 V AC, 5A (*)

Maximum values; 50 W, 24 V DC, 5A (*)

(*): This specification is in case of "-N2". In case of "-N4", maximum switch current capacity is 4 A.

■ Contact input

Type; Non-voltage contact output
 Number; 2 contacts (-N4), 1 contact (-N2)
 Function; Select among Remote 2range switching, Remote 3range switching
 Remote wash start, Remote calibration start, Disable

Remote range switching:

By contact input, mA output is switched to range "2" or range "3". Range "3" is available only to mA1.

Short-circuit resistance (on resistance); maximum 200 Ω
 Open resistance (off resistance); minimum 100k Ω

■ Digital communication (option):

Ethernet (Modbus TCP): 10/100 Mbps
 Cable length: maximum 100 m
 RS-485 (Modbus RTU): 115200/38400/9600 bps
 Cable length:
 115200 bps: maximum 600m
 38400 bps, 9600 bps: maximum 1200m

■ Analog Input (mA, O/I code: -N4)

Temperature compensation (pH, SC)
 Isolated Input: 4 to 20 mA DC
 Accuracy: \pm 0.02 mA
 Number: 1

■ Calibration, wash, diagnosis and other functions

Calibration function:

Zero calibration: Calibration by zero water, Calibration with LED off (if turbidity is over 40NTU)

Slope calibration: Check tool with zero water, standard solution.

Automatic wash/Automatic calibration function:

Need to select code -A5 and prepare a sampling system with membrane filter.

Automatic wash function

Wash cell by tap water*

* Required -A5 Relay box and solenoid valve.

Automatic calibration function

Auto-zero calibration with membrane filtered water

Display maintenance information: Operating time management (Replacement date of desiccant, Light source operating time)

2-3. Mechanical and others

Housing: Aluminum alloy cast

Case

Color; Silver gray

Finish; Chemical resistant coating or high anti-corrosion coating

Window: Polycarbonate

Protection: IP66 NEMA Type 4X (USA), CSA Type 4X (Canada)

Please add Hood option (/H) in case of using outdoor

Size: 165×165×168.5 mm (W×H×D)

Not included cable gland

Weight: Maximum 1.5 kg

Mounting hardware (option):

-Pipe and wall mounting hardware

-Panel mounting hardware

Hood (option):

-Stainless steel

-Stainless steel with chemically resistant coating

Terminal screw size; M3 (Earth terminal: M4)

Cable gland: 8 holes, M20 Cable gland x 8
(For 6 to 12 mm outer diameter cable)

Note: Please screw up them by yourself

Conduit adopter (option): G1/2, 1/2NPT or M20 x 1.5

Note: Please order required numbers.

Stainless Steel Tag Plate (option): In case you specified Option code /SCT, Tag plate on which is the number is printed is shipped with product. You can attach this tag by wire.

Warm up time: Approx. 30 min

Installation/Storage environment:

Ambient Operating Temperature; -20 to 55°C

Storage Temperature; -30 to 70°C

Humidity; 10 to 90 % RH at 40°C

(No condensation)

2-4 Safety standard, EMC and RoHS

Safety:

EN 61010-1, 61010-2-030

UL 61010-1, 61010-2-030

CSA C22.2 No.61010-1, 61010-2-030

GB30439

Installation altitude: 2000 m or less

Overvoltage Category (IEC 61010): II (*)

Pollution level (IEC 61010): 2 (**)

(*): Installation category, called over-voltage category, specifies impulse withstand voltage.

Equipment with Category II is energy-consuming equipment to be supplied from the fixed installation.

(**): Pollution level shows the level of existing the solid, liquid and gas which break electrical isolation. Category 2 is applied to normal room environment.

EMC:

EN 61326-1 Class A, Table 2 (For use in industrial locations)

EN61326-2-3

EN61000-3-2

EN IEC 61000-3-2

EN61000-3-3

RCM: EN 55011 Class A, Group 1

Korea Electromagnetic Conformity Standard

한국 전자파적합성 기준 Class A

Environmental regulation:

RoHS: EN IEC 63000

Information of the WEEE Directive

This product is purposely designed to be used in a large scale fixed installations only and, therefore, is out of scope of the WEEE Directive. The WEEE Directive does not apply.

The WEEE Directive is only valid in the EU.

■ Model & Suffix Codes

TB820D Right Angle Scattered Light Turbidity Detector

Model	Suffix code	Option code	Description
TB820D	Right Angle Scattered Light Turbidity Detector
Light source	- NT - FN	660nm, Formazin, 0-0.2 NTU to 0-500 NTU 860nm, Formazin, 0-0.2 FNU/NTU to 0-700 FNU/NTU
Type	- AB - AD - AG - AJ	General purpose for CE, RCM, China standard General purpose for CSA General purpose for KC General purpose
Relay box for solenoid valve	-NN -A5	Without relay box for solenoid valve Relay box for solenoid valve (*1)
Ultrasonic cleaning	-NN -U1	Without ultrasonic cleaning Oscillator for ultrasonic cleaning (*2)
Check tool	-CT	With Check tool
—	-NN	Always -NN
Option		/L02 /L03 /L05 /L10 /L20 /SCT /U /CB3 /CD3 /CF3 /D1 /D2 /D3 /TC /TCN /NPT	Connection cable for analyzer 2 m (*3) Connection cable for analyzer 3 m (*3) Connection cable for analyzer 5 m (*3) Connection cable for analyzer 10 m (*3) Connection cable for analyzer 20 m (*3) Stainless steel tag plate Pipe mounting hardware (SUS) (*4) Conduit adapter G1/2×3 pcs (*9) Conduit adapter 1/2 NPT×3 pcs (*9) Conduit adapter M20×1.5×3 pcs (*9) Pressurized head tank for low turbidity (for 2 NTU or less) (*7) Simple head tank (for over 2 NTU to 10 NTU) (*7) Head Tank (for over 2 NTU) (*7) One-touch connector (8 mm OD) (*5)(*8) One-touch connector (1/4 inch OD) (*5) (*8) ANSI standard connection (*6) (*8)

- *1. Relay box for solenoid valve and its pipe mounting hardware are supplied with the product. 1 m cables (for power supply, for communication) to connect between the detector and the relay box are also included. Detector with the relay box for solenoid valve can connect to only 1st Input of FLXA402T. Solenoid valve is not supplied with the product. Purchase separately an appropriate solenoid valve and the cables for the solenoid valve. See ● Solenoid valve (SV1 to SV4).
- *2. When “-U1” for Ultrasonic cleaning is selected, order PG400 (Pulse Generator for Clean Unit) separately. Neither Ultrasonic oscillator cables nor power cable are supplied with the product. Purchase them separately. See [GS 19C01B05-01EN](#).
- *3. 1 m cable is supplied with the product. Select this code for other cable length to change if necessary.
- *4. Wall mounting is available to standard model. See ● Mounting Hardware. For the pipe mounting, dedicated hardware are required. See ● Mounting Hardware.
- *5. Three one-touch connectors for tube are supplied with the product. /TC corresponds to the tubes with outside diameter of 8 mm. /TCN corresponds to the tubes with outside diameter of 1/4 inch.
- *6. When option “/NPT” is specified, the piping connections of sample inlet, sample outlet, and drain port are all 1/2 NPT. If /NPT is not specified, they are all Rc1/2.
- *7. The turbidity meter requires an installation of a head tank in front of the sample inlet. Customers have to arrange a head tank by themselves or specify one of the Option codes among /D1, /D2, /D3. /D1 is recommended for 2.0 NTU or less low turbidity. /D3 is recommended for over 2 NTU sample. If the sample is 2 NTU or above, 10 NTU or less, /D2 Simple head tank is also available. Piping head tank uses ISO standard screws and tubes at inlet/outlet.
- *8. Select only one among /NTP, /TC, /TCN.
- *9. See ● Required number of conduit adapters. When “-AD” (CSA) and /C□□ (Conduit adapter) are selected, a plate for the smart unit comes with the product. You need to install the plate before attaching conduit adapters.

● Accessories

Name	Q'ty	Remarks
Desiccant	1	4 pcs/Q'ty (Part number: K9657RJ)
Check tool	1	
Silicone Cloth	1	
Plug	2	

● Spare parts

Name	Part No.	Description	Frequency of Replacement
LED (red light)	K8003DN	for -NT, 660 nm Light source	3 years
LED (Infrared light)	K8003DP	for -FN, 860nm Light source	3 years
Desiccant *	K9657RJ		Yearly
Gasket	K8003NS		Yearly
FUSE	A1633EF		—
FUSE	A1624EF	for -A5 The relay box uses two fuses.	—
Filter Element, 1 μm	K9008ZD		Yearly
Filter Element, 0.2 μm	K9726EH		Yearly

* Use within a year after purchasing.

● Head Tank

Name	Part No.	Description
Pressurized head tank for low turbidity	K8003WA	2 NTU or less, same as option code /D1
Simple head tank	K8003YA	over 2NTU to 10NTU, same as option code /D2
Head tank	K8003YR	over 2 NTU, same as option code /D3

● Other parts

Regarding recommended solenoid valve, refer to Piping diagram.

● Mounting Hardware (Option)

Select each corresponding hardware based on the table below.

Model	Mounting type		
	Wall	Pipe	Panel
TB820D	Unselected (standard)	/U (Pipe mounting)	NA
FLXA402T	/UM* or /U	/UM* or /U	/UM* or /PM

*: Universal mounting kit (/UM) contains pipe, wall mounting hardware (/U) and panel mounting hardware (/PM).

● Required Number of Conduit Adapters

If you need to provide conduit work with cables, specify the conduit adapter by Option code.

Conduit adapters and dedicated cable glands, which are used in place of the standard cable gland for cable entry holes, are supplied with the product.

You can specify the conduit adapter by Option code for both TB820D and FLXA402T, however, be aware of the following.

- (a) When FLXA402T Digital communication “-E” (Modbus TCP/IP) is selected
If you attach a conduit adapter on the Modbus TCP/IP cable entry, you need an Ethernet dedicated conduit adapter. Be sure to specify FLXA402T “/C□6”.
- (b) When Type of TB820D, FLXA402T is “-AD” (for CSA)
Order a plate described below to install a conduit adapter for “-AD”, otherwise the CSA safety standards will not be satisfied.
For “-AD” (for CSA), specify TB820D “/C□3” on TB820D side.
If “/C□3” is selected, the plate is shipped with the product. Be sure to install the plate on the Smart unit of TB820D.

Next diagram shows the position of each cable entry (●●●) where you can attach conduit adapters for the conduit.

• TB820D-....-NN

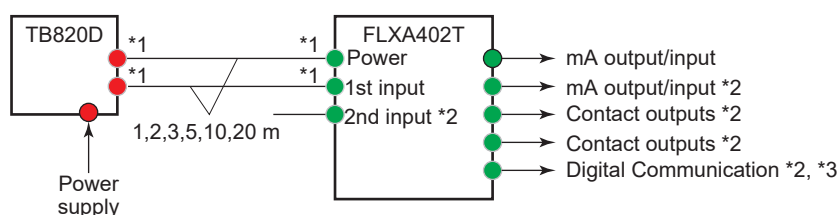

• TB820D-....-A5

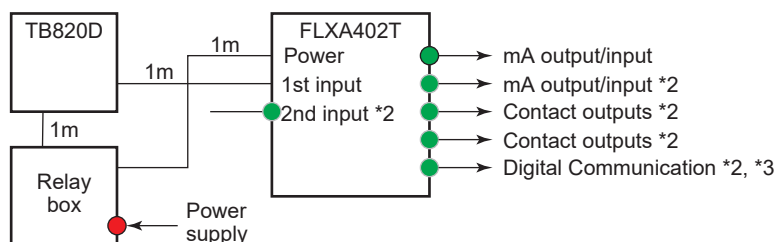

• TB820D-....-NN (-U1)....

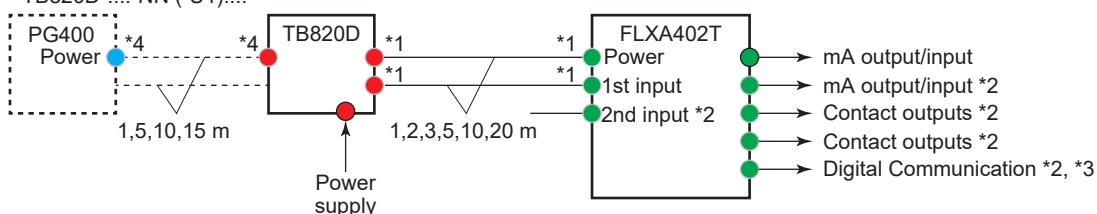

• TB820D-....-A5 (-U1)....

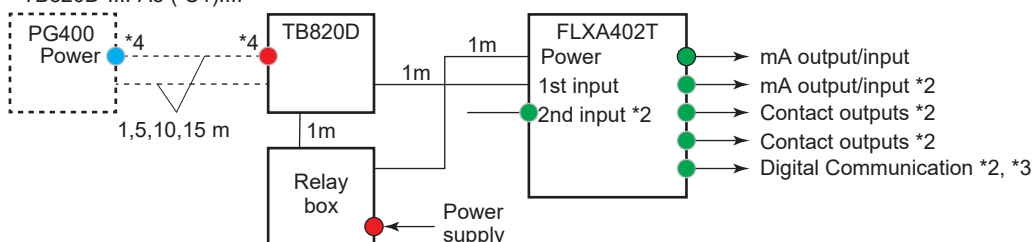

*1: The standard cable length between FLXA402T and TB820D is 1 m. You can change the cable length by specifying a code from Option code.

*2: The number of cable entry holes to be used are defined by the specification as below.

Spec.	2nd Input		mA output/input		Contact Outputs		Digital Communication		
	-NN	the others	-N2	-N4	-WR	-NR	-N	-E	-R
Required No. of cable entry holes	0	1	1	2	2	0	0	1*	1

*: Conduit exclusively for Ethernet

*3: For Ethernet cable, use Ethernet dedicated conduit adapter.

*4: When the cable between PG400 (Pulse generator for clean unit) and TB820D is long, use the conduit adapters on both sides of the cable entry. However, the conduit cannot be used for the oscillator cable.

If you need more conduit adapters to meet the requirement, purchase additionally. See the table below.

Conduit adapter (for additional purchase)

Type	Parts number	Quantity	Remark
G 1/2 (Cable gland for adapter + adapter)	K9703WF	4 set	for Option code /CB□
1/2 NPT (Cable gland for adapter + adapter)	K9703WG	4 set	for Option code /CD□
M 20 x 1.5 (Cable gland for adapter + adapter)	K9703WH	4 set	for Option code /CF□

When you select PG400 "/C□" (conduit adapter), two sets of conduit adapters come with the product. After completing the conduit work on PG400, you can use the unused conduit adapters on TB820/FLXA402T.

- **Solenoid valve (SV1 to SV4)**

Solenoid valve is not supplied with Relay box for solenoid valve. Purchase separately an appropriate solenoid valve.

Requirement for sampling system

	Port size	Valve type	Max. working pressure	Max. Working pressure differential
SV1	Rc 1/2	N.O. (*1)	≥ 1.5 MPa	≥ 0.7 MPa
SV2, 3	Rc 1/4	N.C. (*2)	≥ 5.0 MPa	≥ 0.4 MPa
SV4	Rc 3/8	N.C. (*2)	≥ 2.0 MPa	≥ 1 MPa

*1: Valve closes when energized.

*2: Valve opens when energized.

Example

	Voltage	100 V	200 V	220 V
SV1	Part number	B1043ET	B1045ET	B1046ET
	Model code	VXZ2B2GH	VXZ2B2GK	VXZ2B2GZ1G
	Manufacturer	SMC Corporation		
SV2,3	Part number	B1035ET	B1037ET	B1038ET
	Model code	AB41-02-6-D2GS-AC100V-ST	AB41-02-6-D2GS-AC200V-ST	AB41-02-6-D2GS-AC200V-ST
	Manufacturer	CKD Corporation		
SV4	Part number	B1031ET	B1033ET	B1034ET
	Model code	ADK11-10A-D2GS-AC100V-ST	ADK11-10A-D2GS-AC200V-ST	ADK11-10A-D2GS-AC220V-ST
	Manufacturer	CKD Corporation		

Recommended cable for solenoid valve

Part number	K8004TH (for SV1), K8004TJ (for SV2), K8004TK (for SV3), K8004TL (for SV4)
Cable length	1.2 m
Rated voltage	300 V
Specification	AWG20 2-core cable, M3 round terminal

FLXA402T Liquid Analyzer for Turbidity and Chlorine

Liquid Analyzer FLXA402T is a common analyzer for Turbidity detector and Chlorine sensor unit. The table below for Model and Suffix code (MS code) applies the combination between FLXA402T and TB820D.

Model	Suffix code	Option code	Description
FLXA402T	Liquid Analyzer for Turbidity and Chlorine
Power supply	-A	AC version
Housing (*1)	-B -D	Aluminum alloy cast + urethane coating Aluminum alloy cast + high anti-corrosion coating
Type	-AB -AD -AG -AJ	General purpose for CE, RCM, China standard General purpose for CSA General purpose for KC General purpose
1st Input	-TB	SENCOM SA for Turbidity
2nd Input (*2)	-NN -P1 -C1 -TB	Without Input pH Conductivity (SC) SENCOM SA for Turbidity
mA Output/Input	-N2 -N4	2 x 4-20 mA Output + 1 x Contact Input (without HART) 4 x 4-20 mA Output + 2 x Contact Input + 1 x 4-20 mA Input (without HART)
Contact Outputs	-WR -NR	Contact outputs (Wash and Fail contact outputs) Without Contact outputs (without Wash and Fail contact outputs)
—	-N	Always -N
Digital Communication	-N -E -R	Without Digital communication Modbus TCP/IP Modbus RTU (RS-485)
Country	-N	Global except Japan
Assembled in stanchion	-NN	Not assembled in stanchion
—	-NN	Always -NN
Option	Mounting hardware Hood Tag plate Conduit adapter (*4)	/UM /U /PM /H6 /H7 /SCT /CB4 /CD4 /CF4 /CB6 /CD6 /CF6	Universal mounting kit (*3) Pipe and wall mounting hardware Panel mounting hardware Hood, stainless steel Hood, stainless steel + urethane coating Stainless steel tag plate G1/2 x 4 pcs 1/2 NPT x 4 pcs M20 x 1.5 x 4 pcs G1/2 x 3 pcs + G1/2 for Ethernet x 1 pcs (*5) 1/2 NPT x 3 pcs + 1/2 NPT for Ethernet x 1 pcs (*5) M20 x 1.5 x 3 pcs + M20 for Ethernet x 1 pcs (*5)

*1: Urethane coating is acid resistant. Heavy duty coating is acid/alkali resistant.

*2: SENCOM SA Turbidity is for TB820D. To connect FLXA402T to both a chlorine sensor and a turbidity detector, refer to GS12F05B10-01EN and select “-CL” to 1st Input, “-TB” to 2nd Input.
To detectors connected to 2nd Input, none of the following is available: auto washing, auto zero calibration, wiper cleaning.

*3: Universal mounting kit contains pipe, wall mounting hardware (/U) and panel mounting hardware (/PM).

*4: See ● Required Number of Conduit Adapters.

*5: Available only when “-E” (Modbus TCP/IP) to Digital communication is selected.

■ Optional parts

Name		Parts number	Quantity	Remark
Mounting hardware	for pipe, wall mounting (stainless)	K9703SS	1 set	same as Option code /U
	for panel mounting (stainless)	K9703ZD	1 set	same as Option code /PM
Sun shade hood	Stainless	K9698WK	1 set	same as Option code /H6
	stainless + urethane	K9698WL	1 set	same as Option code /H7
Rubber plug attachment		K9334CN	1 pcs	for Cable gland
Fuse		A1633EF	1 pcs	250V/2.5A (minimum 5 pcs)
SD card		A1019NL	1 pcs	2 GB industrial SD card Customers can provide the cards with spec: Storage capacity: 128 MB or greater Type: SD, SDHC (with power failure recovery)

■ Dimensions

TB820D Right Angle Scattered Light Turbidity Detector

Unit: mm

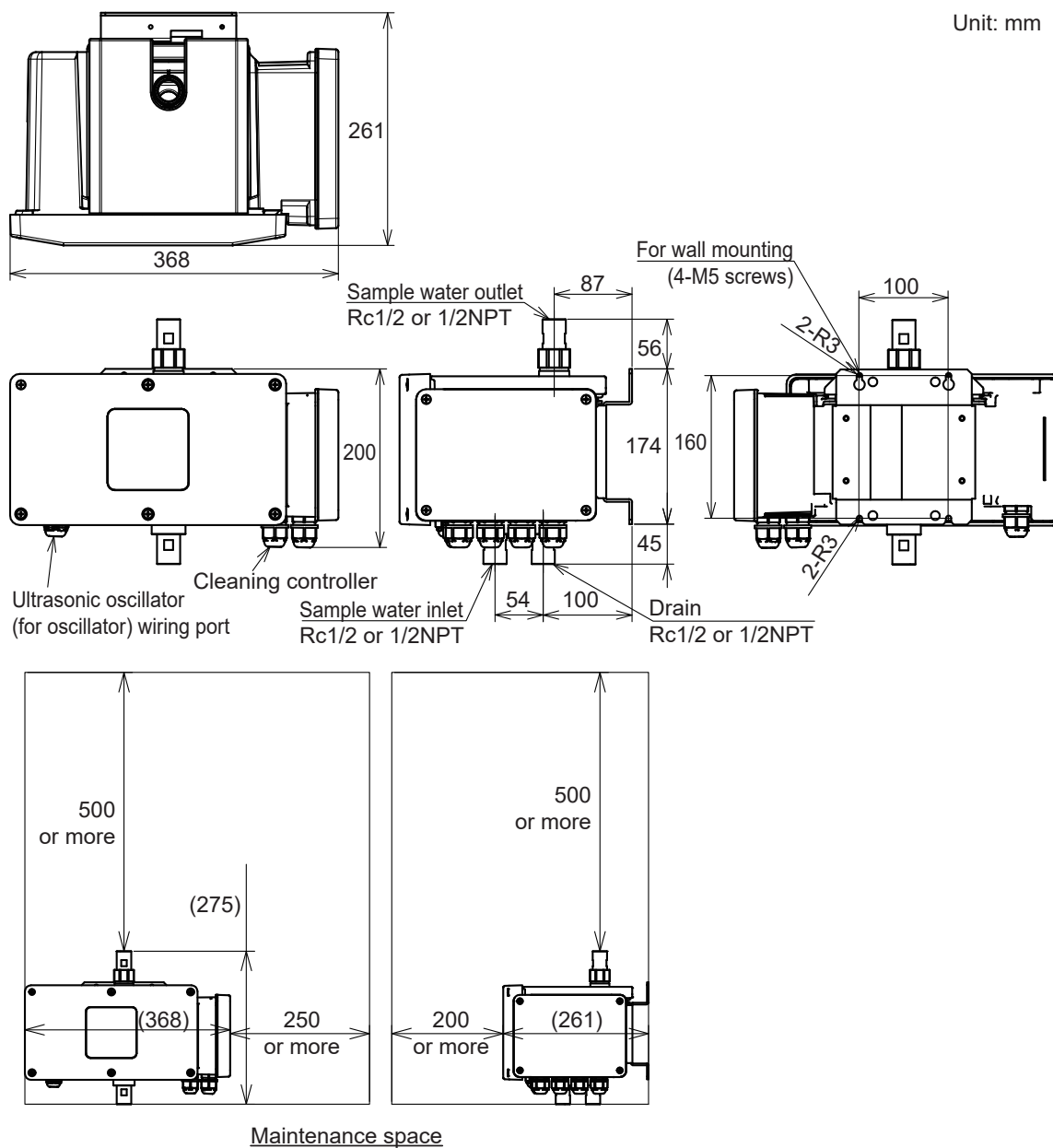

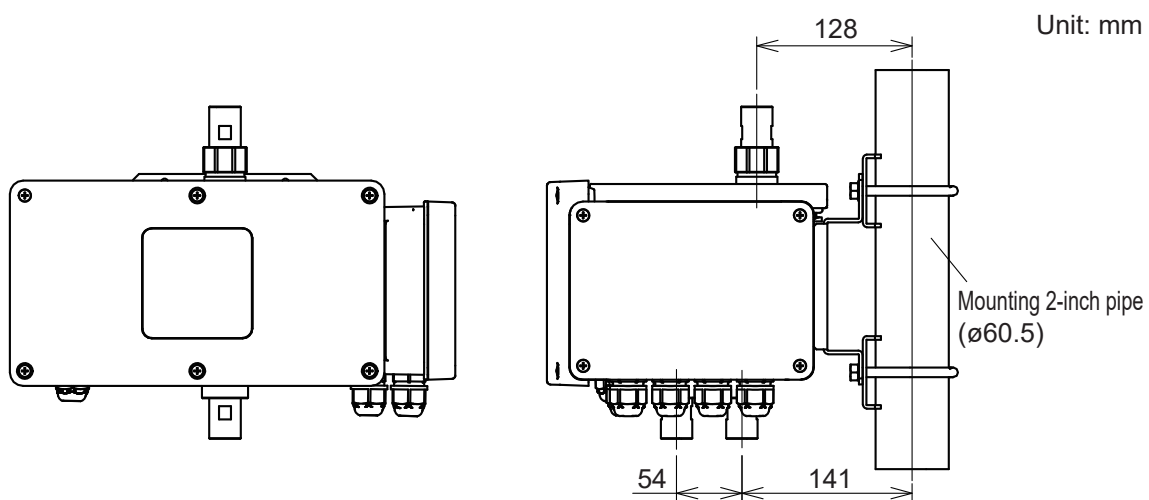
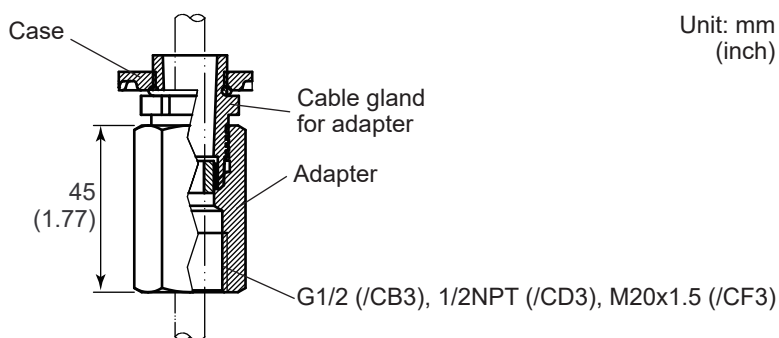
● Pipe mounting (/U)**● Conduit adaptor (/CB3, /CD3, /CF3)**

● Relay box for solenoid valve (TB820D-□□-□□-A5-□□-□□-NN)

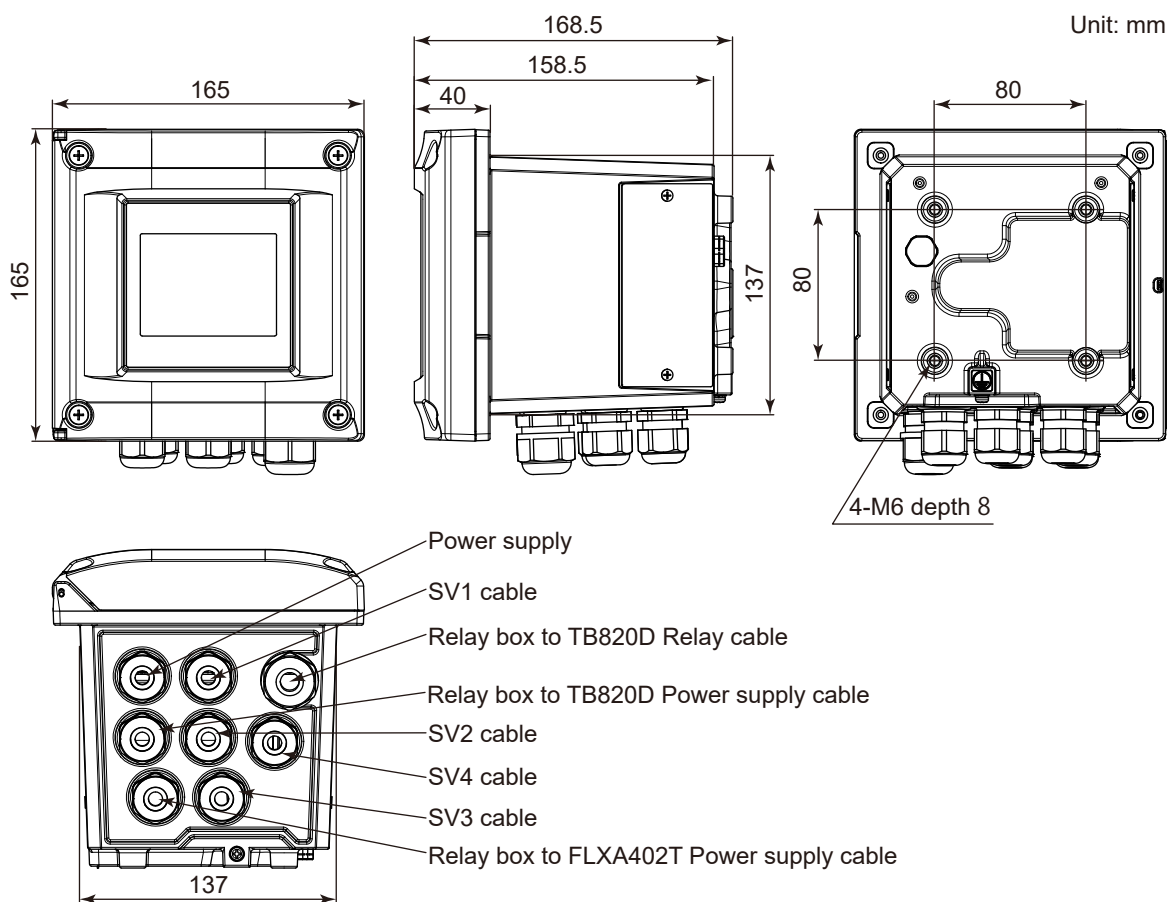

● Pressurized head tank for low turbidity (/D1)

Unit: mm

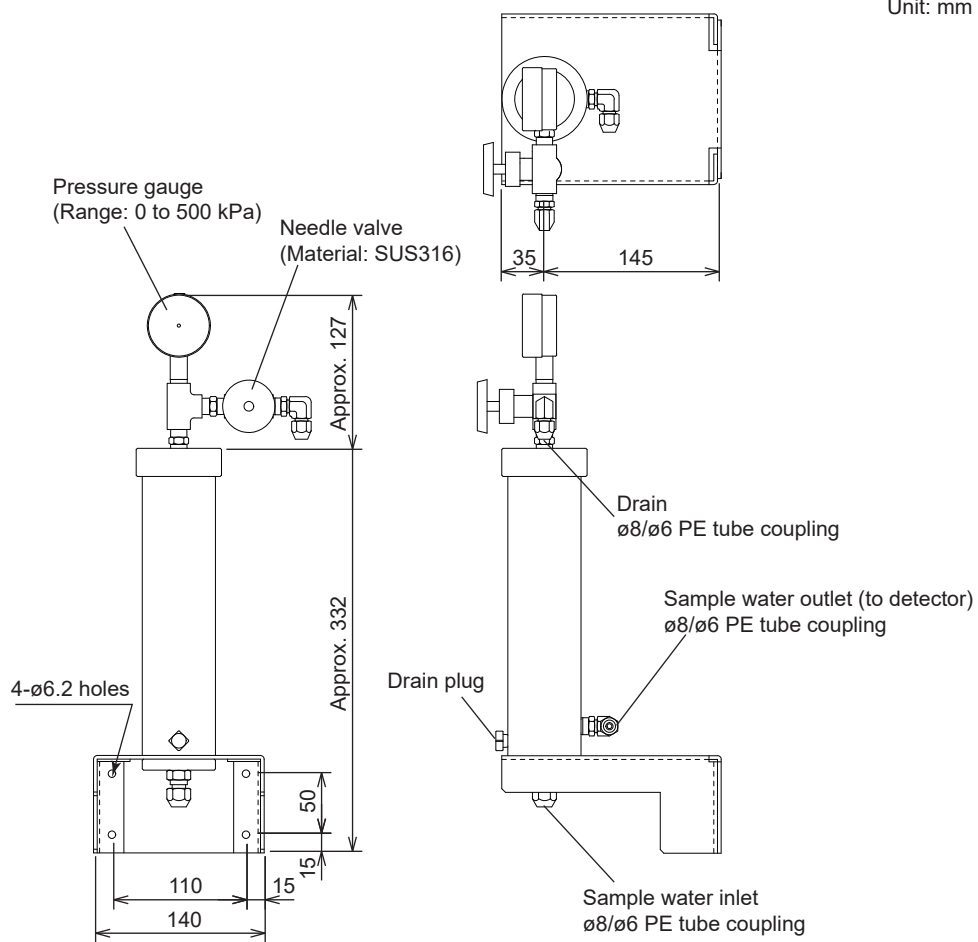

● Simple head tank (for NTU to 10.0 NTU) (/D2)

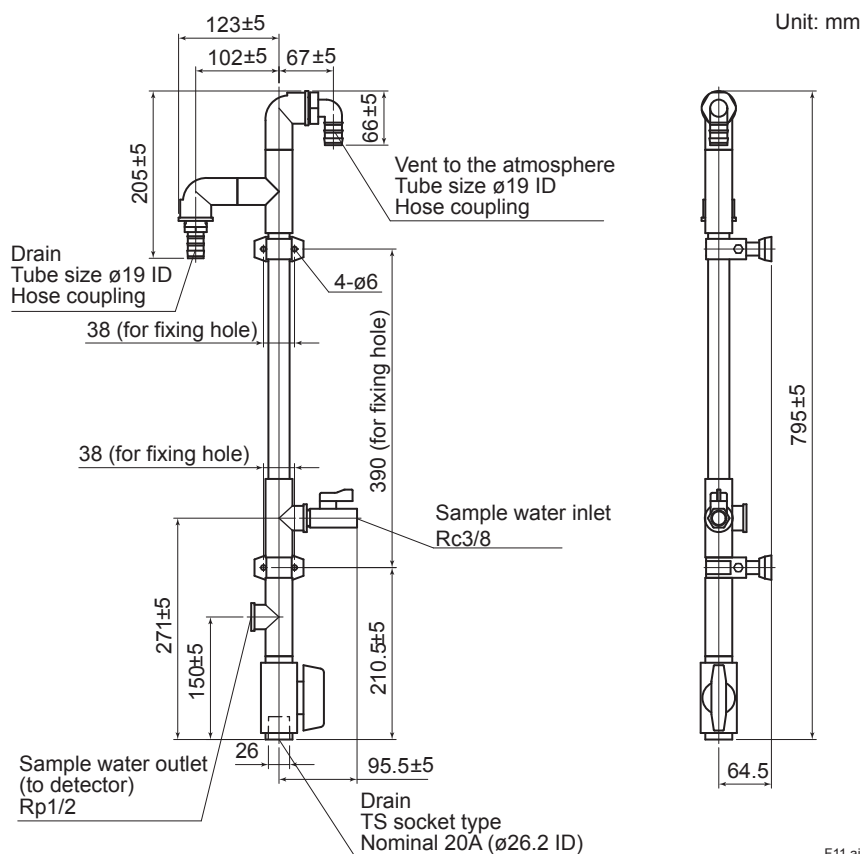

● Head tank (for over 2 NTU) (/D3)

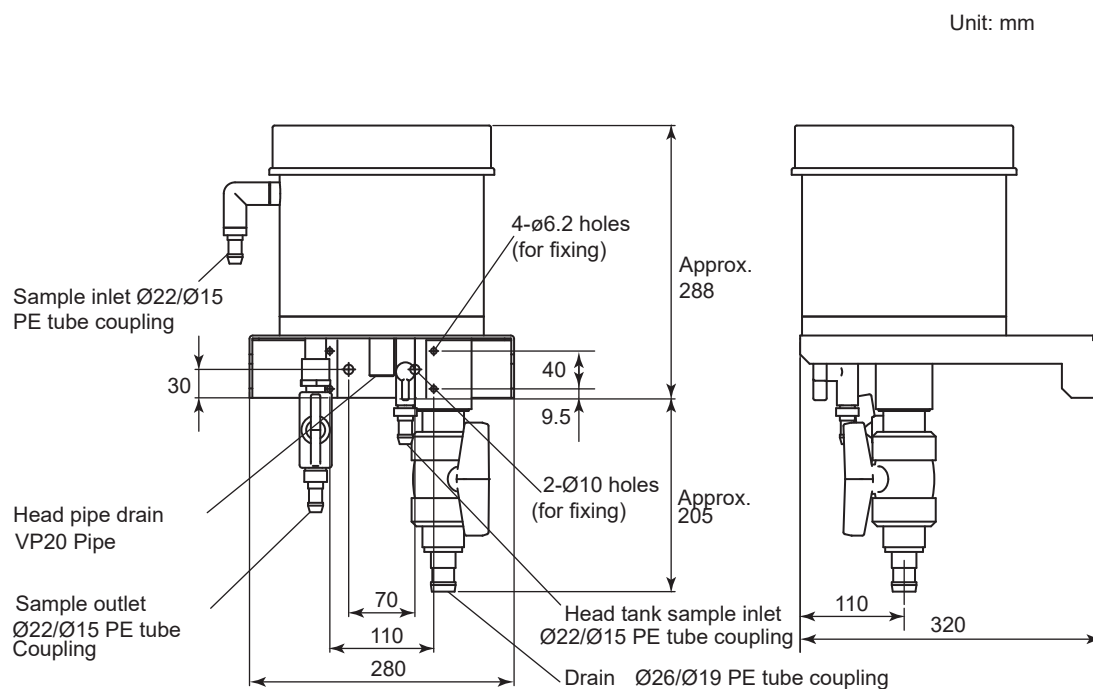

● Zero Turbidity Filter assembly

Unit: mm

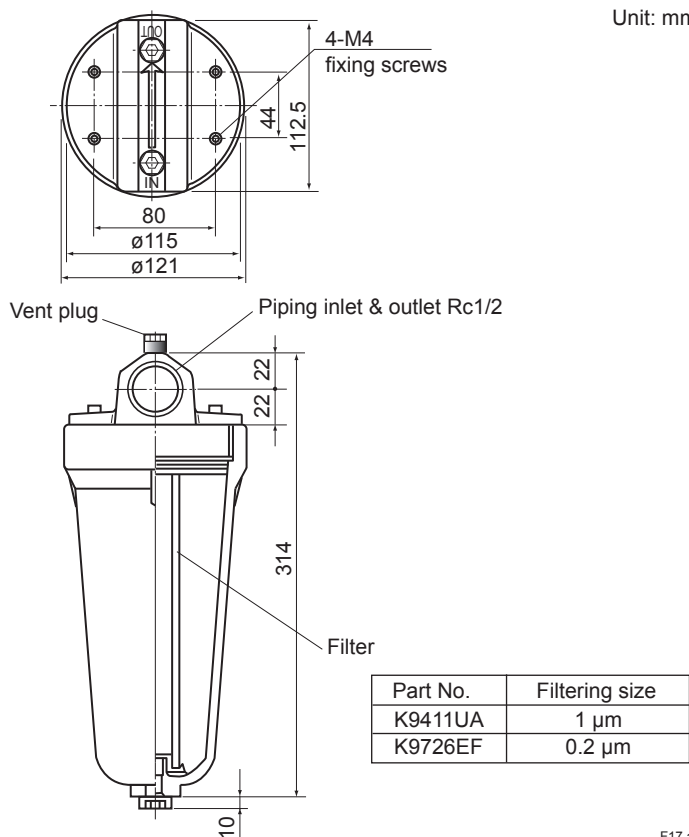

Part No.	Filtering size
K9411UA	1 μm
K9726EF	0.2 μm

F17.ai

FLXA402T Liquid Analyzer for Turbidity and Chlorine

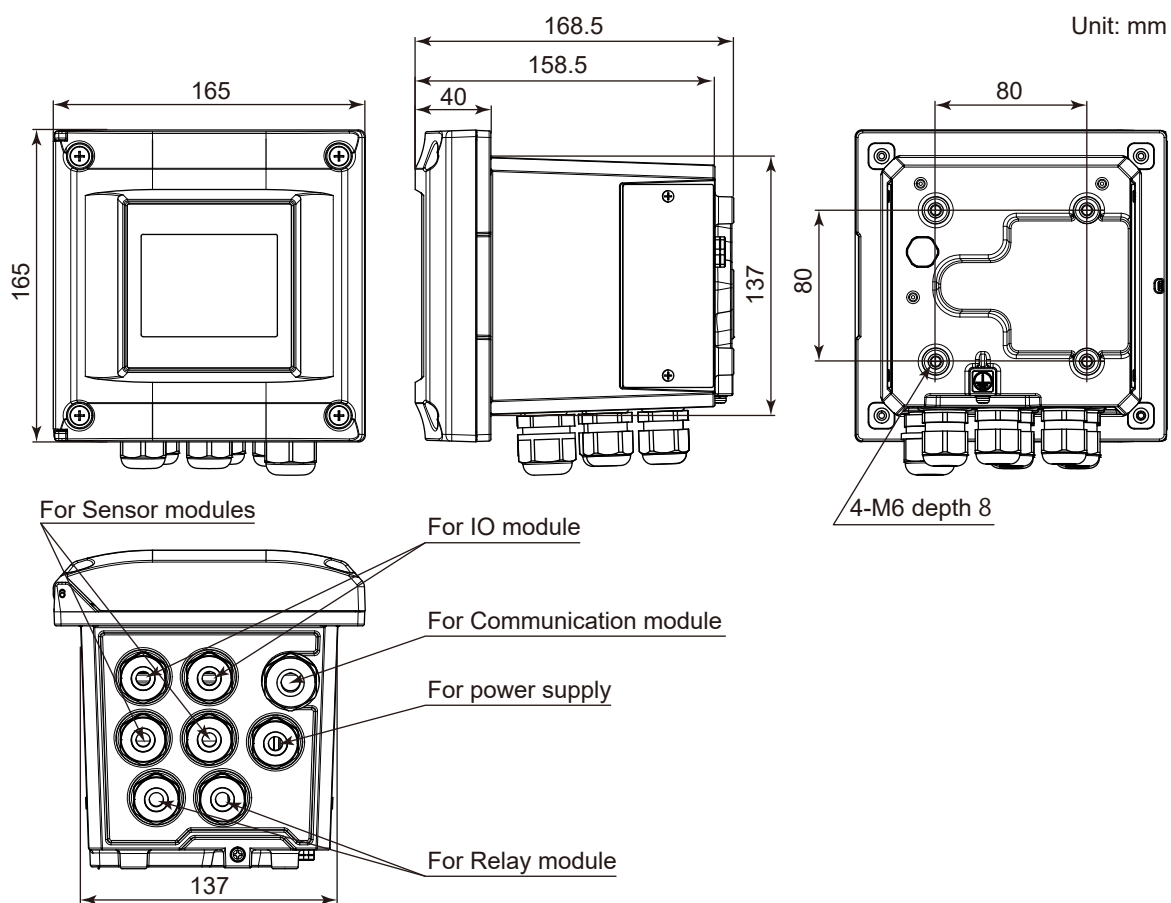

Conduit adaptor (/CB4, /CD4, /CF4/, /CB6, /CD6, /CF6)

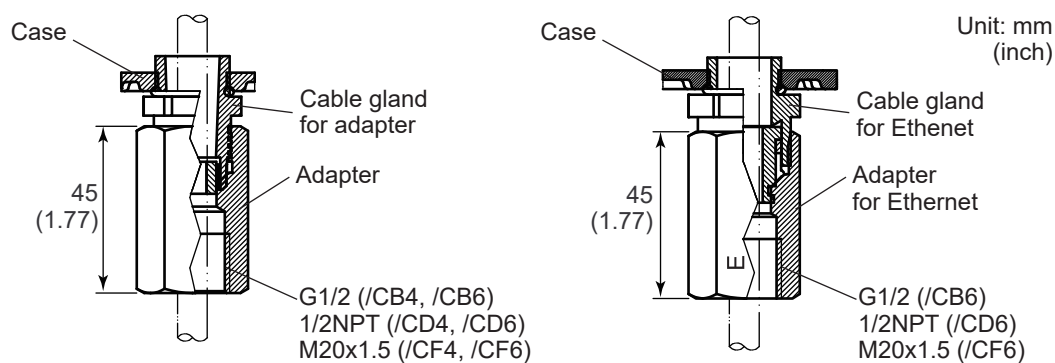

Note: Universal Mounting kit (/UM) contains pipe, wall mounting hardware (/U) and panel mounting hardware (/PM).

● Panel mounting hardware (/PM, /UM)

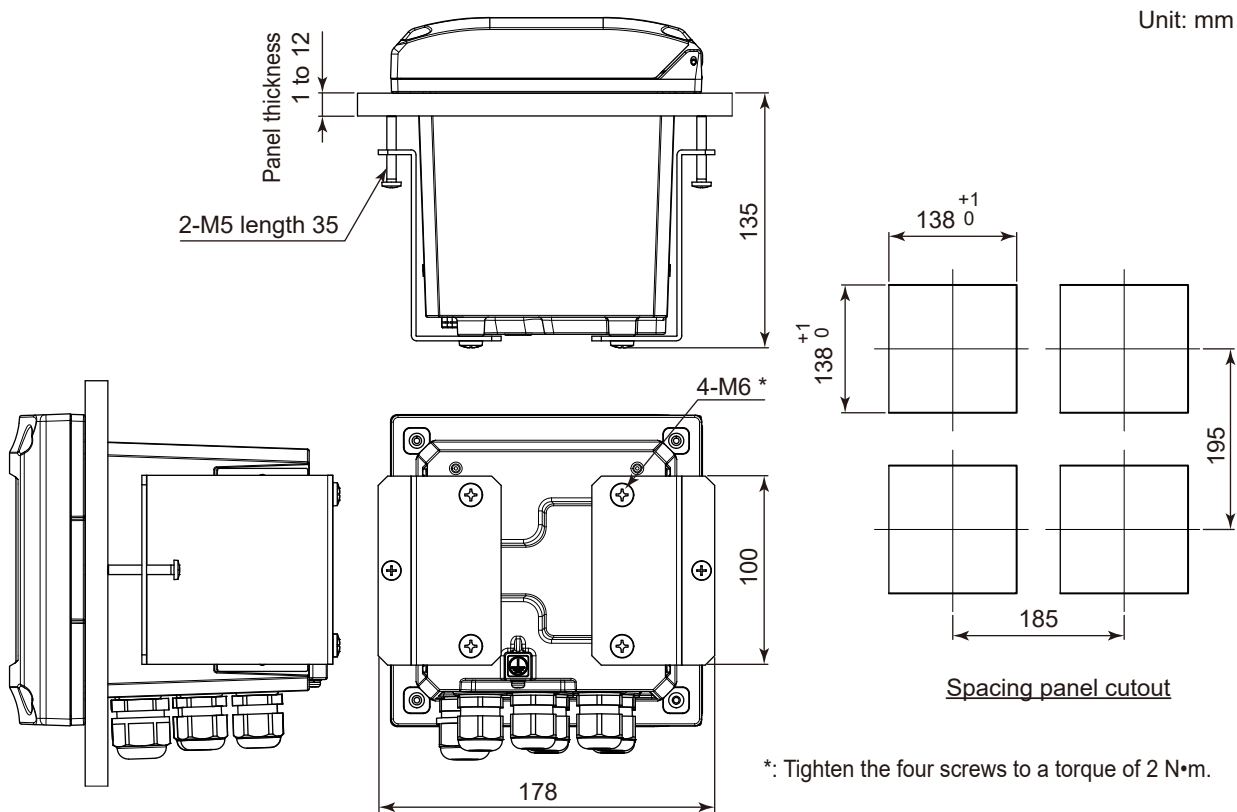

● Wall mounting hardware (/U, /UM)

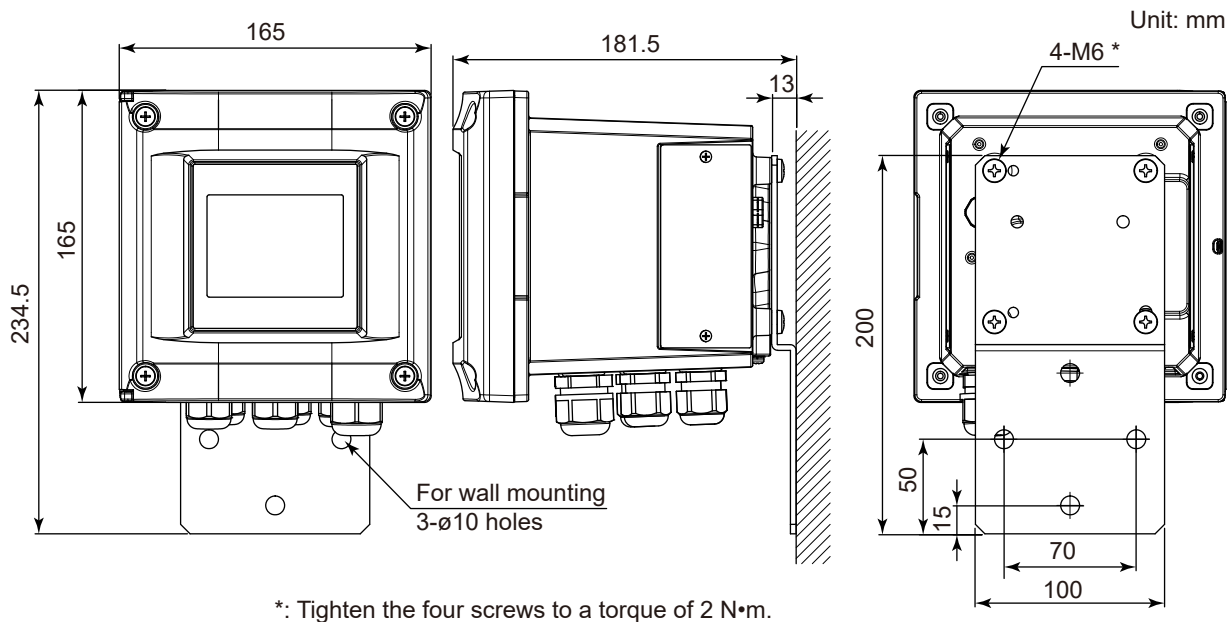

Note: For wall mounting, the wall should be strong enough to bear the weight of 8 kg or more.

● Pipe mounting hardware (/U, /UM)

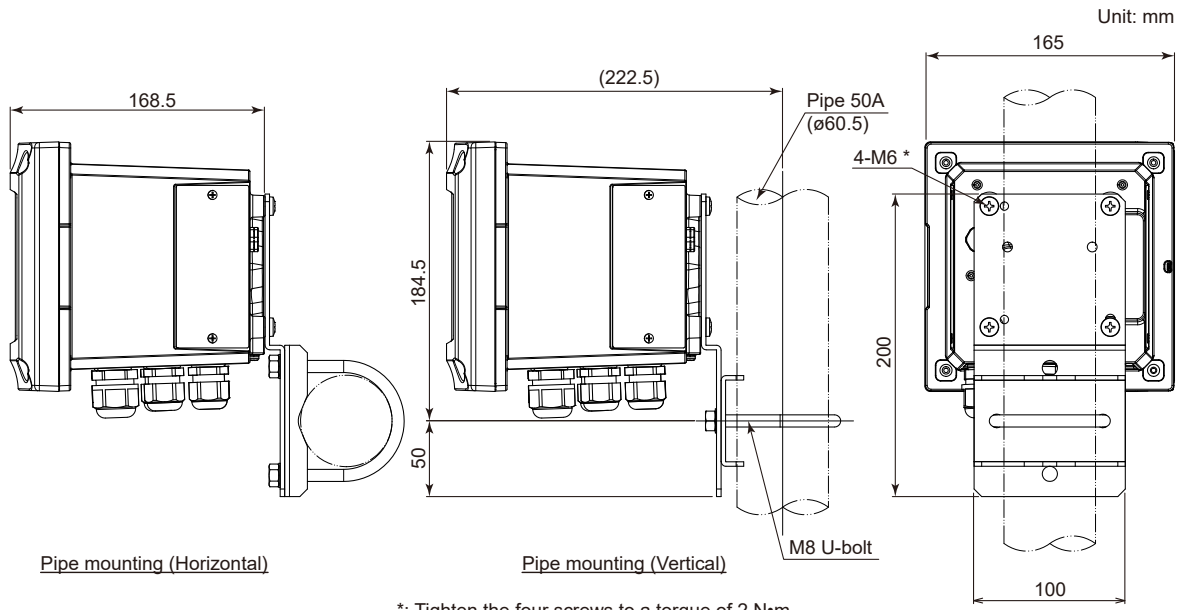

*: Tighten the four screws to a torque of 2 N•m.

● Hood Stainless steel (/H6, /H7)

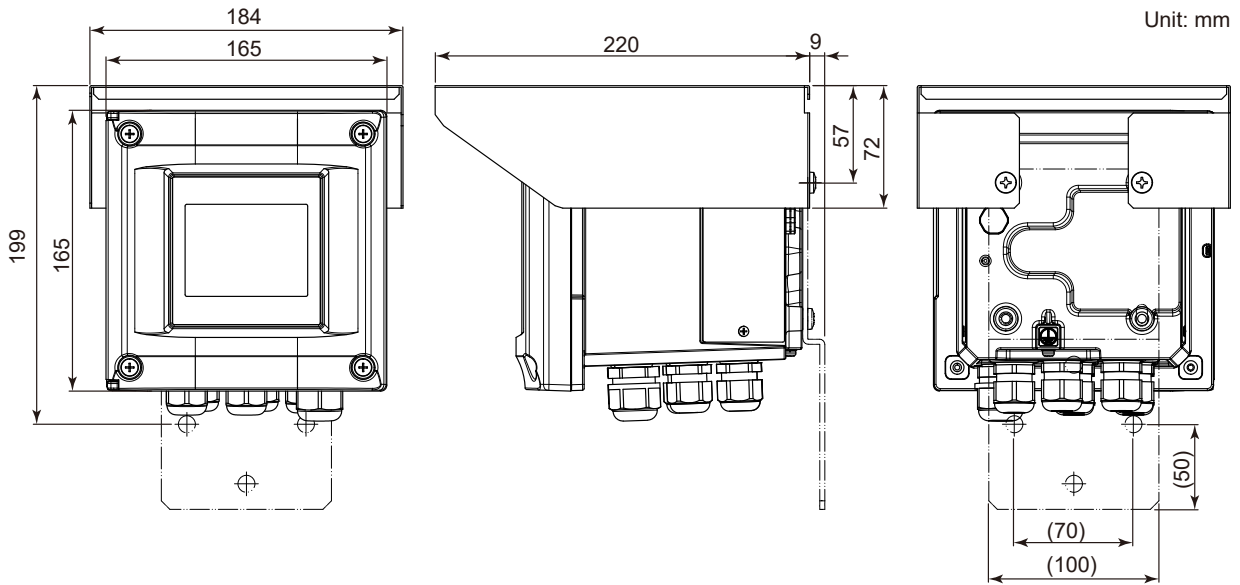

■ Wiring

TB820D-□□-□□-NN

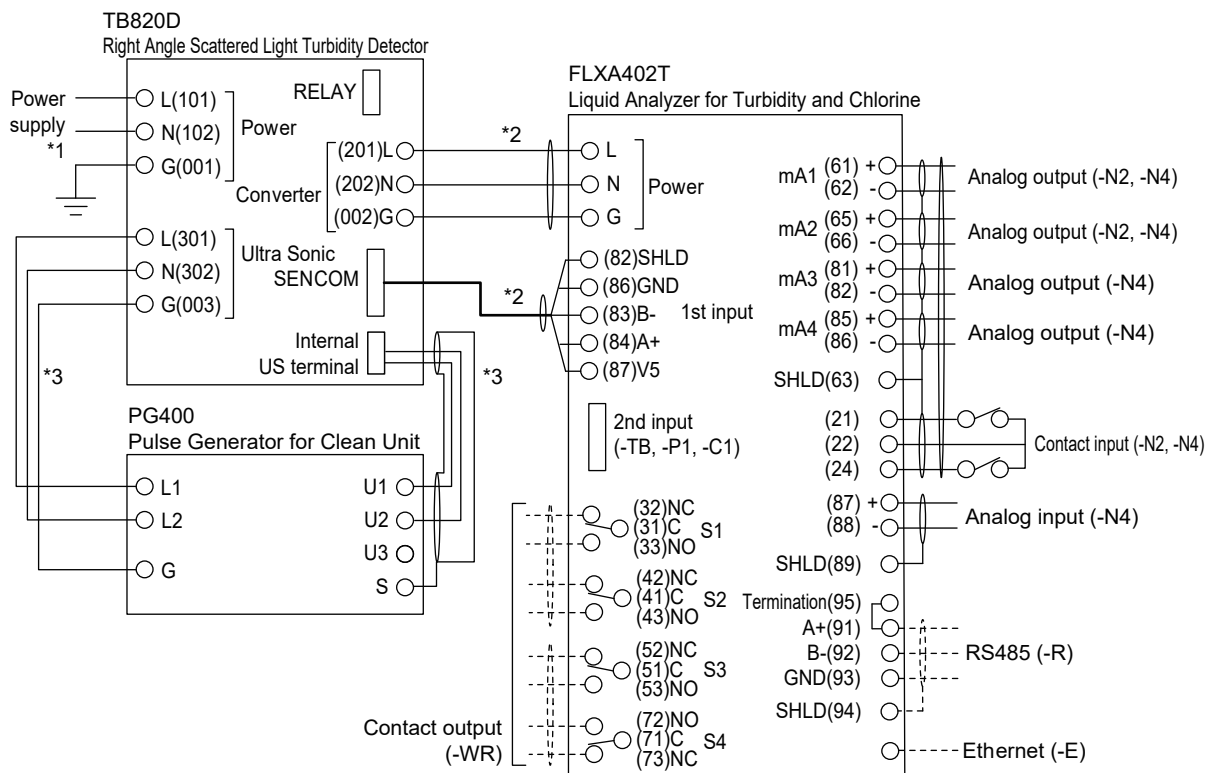

- *1: Power terminal "G" on TB820D must be grounded (ground resistance: 100 ohm or less).
In case of selecting -NN as Relay box for solenoid valve, power supply cable connects with L(101), N(102) and G(001) in TB820D.
- *2: The connection cables are 1 m in length normally.
They are available with /L02, /L03, /L05, /L10 or /L20 depending on the length you need.
- *3: When suffix code -U1 is specified, PG400 should be purchased separately.
Neither Ultrasonic oscillator cables nor power cable are supplied with the product. Purchase them separately.
See GS 19C01B05-01EN.

TB820D-□□-□□-A5

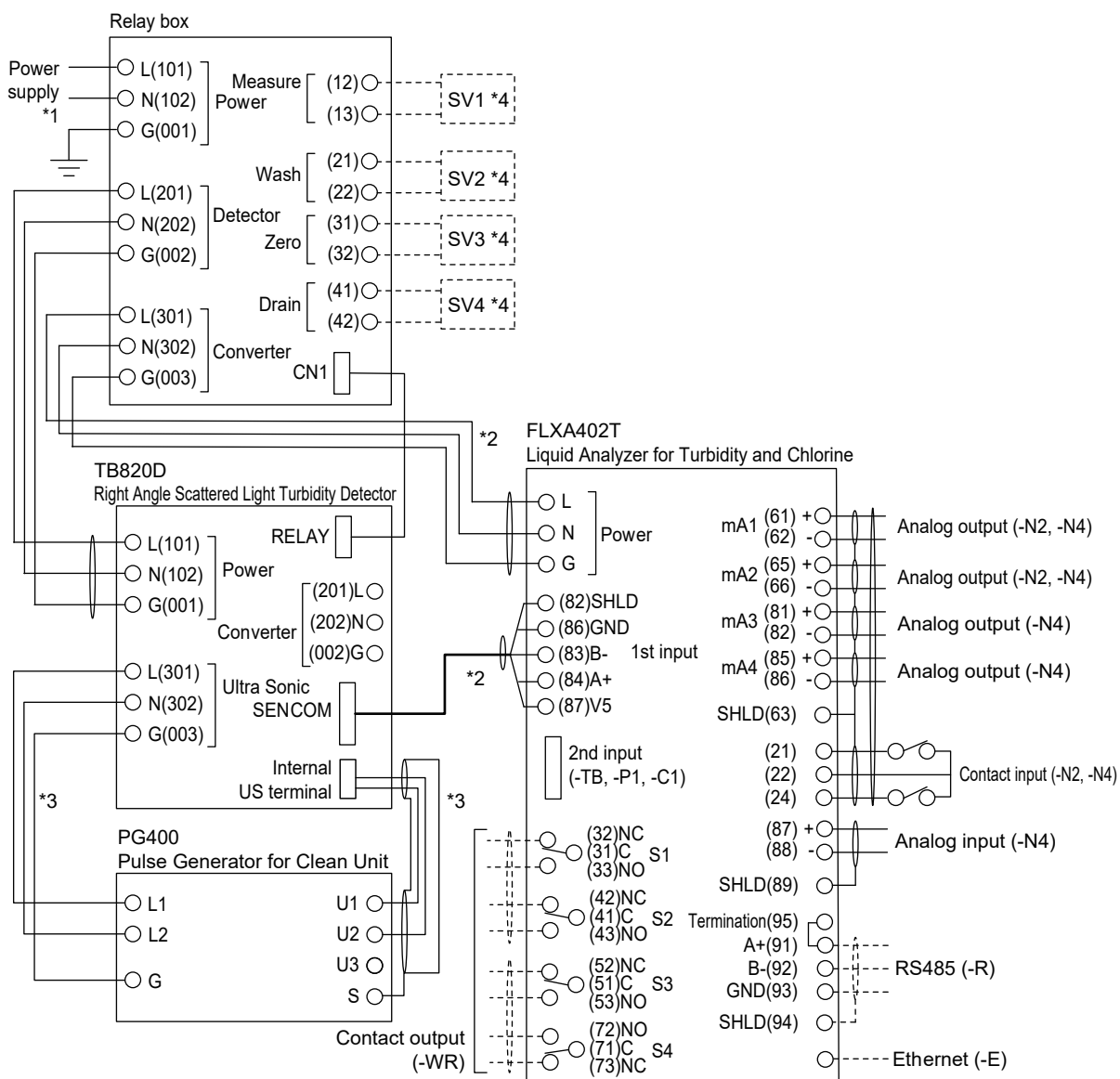

- *1: Power terminal "G" on Relay box must be grounded (ground resistance: 100 ohm or less).
In case of selecting -A5, power supply cable connects with L(101), N(102) and G(001) in Relay box.
- *2: Connection cables are 1 m in length normally.
They are available with /L02, /L03, /L05, /L10 or /L20 depending on the length you need.
- *3: When suffix code -U1 is specified, PG400 should be purchased separately.
Neither Ultrasonic oscillator cables nor power cable are supplied with the product.
Purchase them separately. See GS 19C01B05-01EN.
- *4: In case of selecting -A5, purchase the solenoid valve corresponding input power supply and frequency.
See ● Solenoid valve (SV1 to SV4).

■ Piping

Pressurized head tank for low turbidity /D1
(Manual cleaning, manual zero calibration)

- DG1: Pressurized head tank for low turbidity
 F1: Zero turbidity filter 1 μ m
 F2: Zero turbidity filter 2 μ m
 BV1, 2, 4, 9, 10: Ball valve
 PR1: Pressure regulator
 NV1, 2, 3: Needle valve
 P1: Pressure gauge

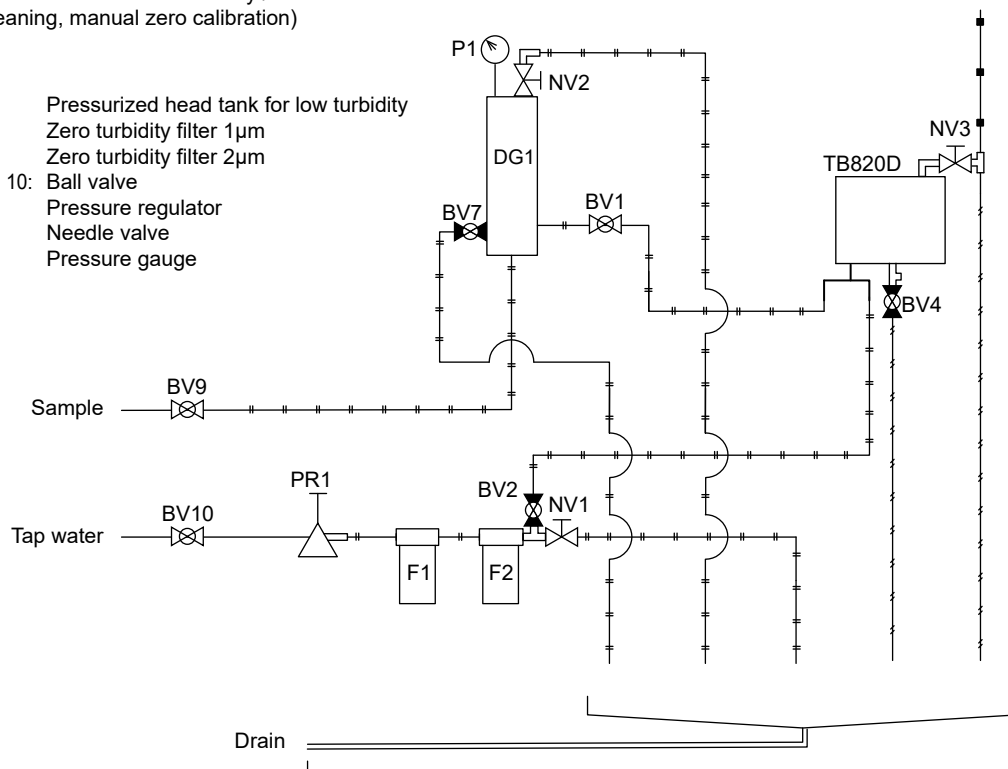

- <PIPE> ———— \varnothing 8/ \varnothing 6 Polyethylene tube
 —■—■—■ \varnothing 12/ \varnothing 9 Polyethylene tube
 —x—x—x \varnothing 22/ \varnothing 15 Flexible mesh-reinforced tube
 —□—□—□ \varnothing 26/ \varnothing 19 Flexible mesh-reinforced tube
 —x—x—x \varnothing 33/ \varnothing 25 Flexible mesh-reinforced tube

Simple Head Tank /D2
(Manual cleaning, manual zero calibration)

HT: Simple head tank
 F1: Zero turbidity filter 1 μ m
 BV1, 2, 4, 5, 7, 9, 10: Ball valve
 PR1: Pressure regulator
 NV1: Needle valve

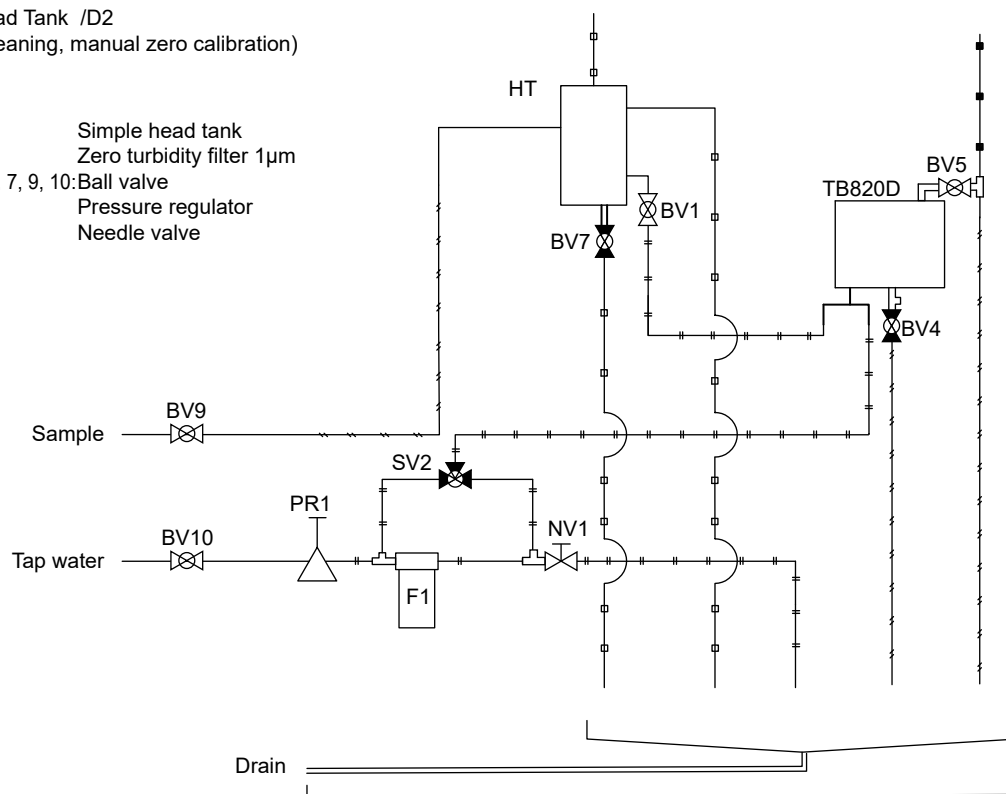

<PIPE> ———— ϕ 8/ ϕ 6 Polyethylene tube
 —■—■—■ ϕ 12/ ϕ 9 Polyethylene tube
 ———— ϕ 22/ ϕ 15 Flexible mesh-reinforced tube
 —■—■—■ ϕ 26/ ϕ 19 Flexible mesh-reinforced tube
 —■—■—■ ϕ 33/ ϕ 25 Flexible mesh-reinforced tube

Head Tank /D3
(Manual cleaning, manual zero calibration)

HT: Open head tank
 F1: Zero turbidity filter 1 μ m
 BV1, 2, 4 to 7, 9, 10: Ball valve
 PR1: Pressure regulator
 NV1: Needle valve

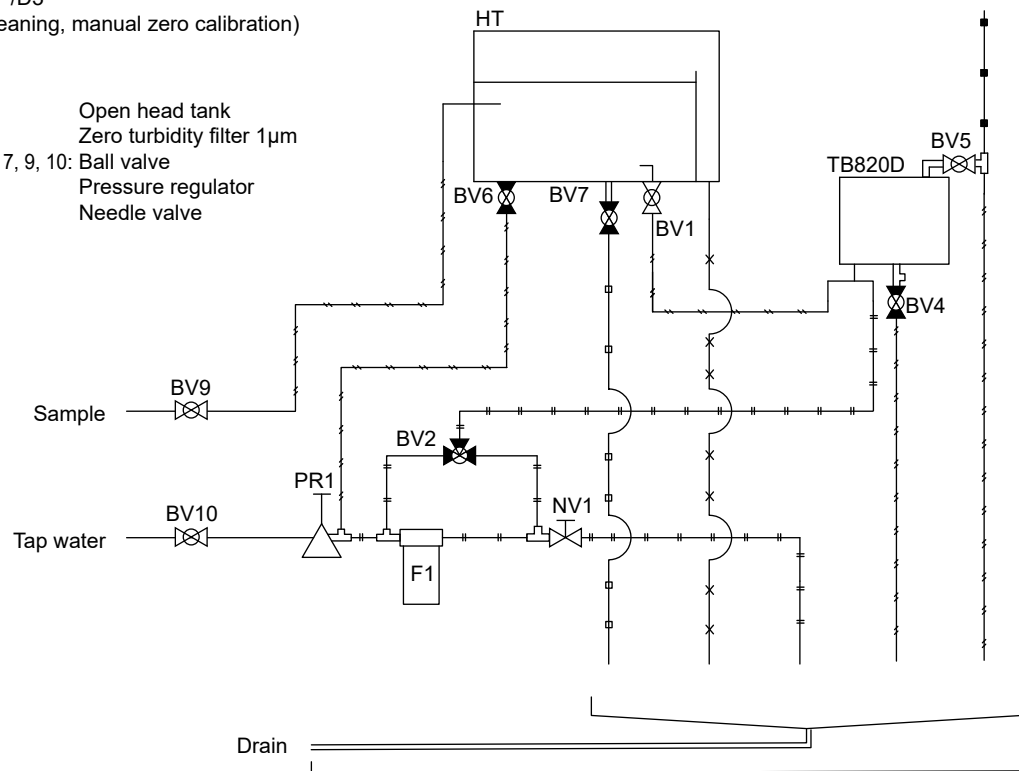

<PIPE> ———— \varnothing 8/ \varnothing 6 Polyethylene tube
 —■—■— \varnothing 12/ \varnothing 9 Polyethylene tube
 —x—x— \varnothing 22/ \varnothing 15 Flexible mesh-reinforced tube
 —□—□— \varnothing 26/ \varnothing 19 Flexible mesh-reinforced tube
 —x—x— \varnothing 33/ \varnothing 25 Flexible mesh-reinforced tube

Head Tank /D3
(Automatic cleaning, manual zero calibration)

HT: Open Head Tank
 F1: Zero turbidity filter 1 μ m
 BV3 to 7, 9, 10: Ball valve
 SV1, 2, 4: Solenoid valve
 PR1: Pressure regulator
 NV1: Needle valve

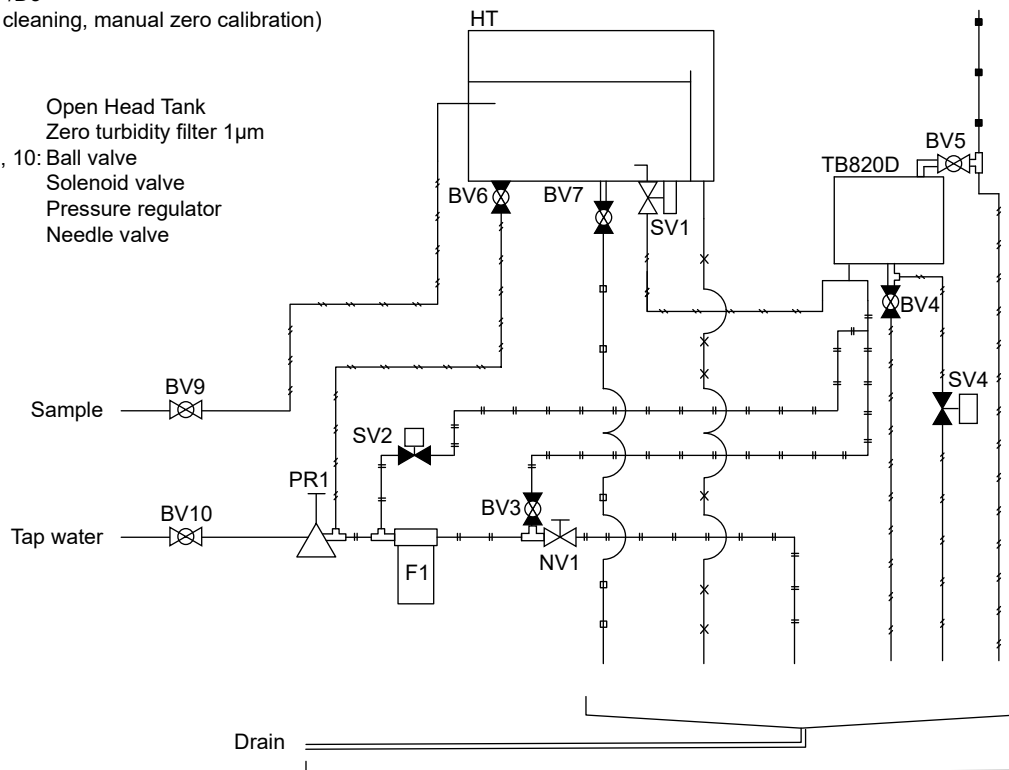

<PIPE> ———— $\phi 8/\phi 6$ Polyethylene tube
 —■—■— $\phi 12/\phi 9$ Polyethylene tube
 —x—x— $\phi 22/\phi 15$ Flexible mesh-reinforced tube
 —□—□— $\phi 26/\phi 19$ Flexible mesh-reinforced tube
 —x—x— $\phi 33/\phi 25$ Flexible mesh-reinforced tube

Note: Regarding requirement of solenoid valve, see ● Solenoid valve (SV1 to SV4).

Head Tank /D3
(Automatic cleaning, automatic zero calibration)

HT: Open head tank
F1: Zero turbidity filter 1 μ m
BV4 to 7, 9, 10: Ball valve
SV1 to 4: Solenoid valve
PR1: Pressure regulator
NV11: Needle valve

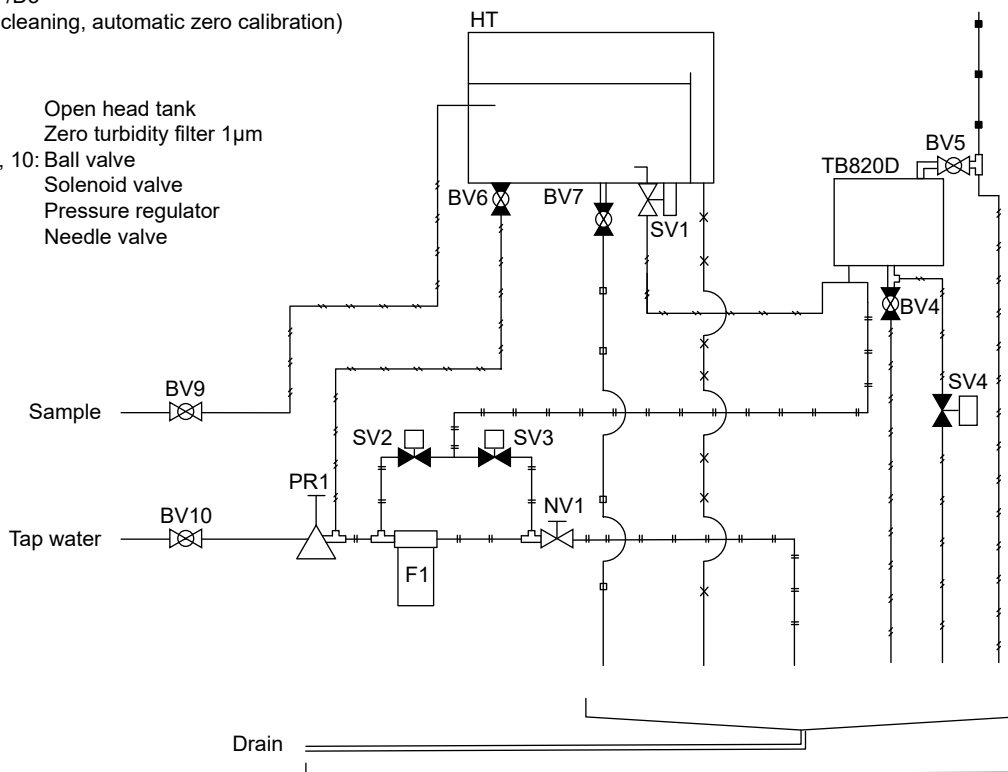

<PIPE> ———— $\phi 8/\phi 6$ Polyethylene tube
 —■—■—■— $\phi 12/\phi 9$ Polyethylene tube
 - - - - - $\phi 22/\phi 15$ Flexible mesh-reinforced tube
 -□-□-□- $\phi 26/\phi 19$ Flexible mesh-reinforced tube
 -x-x-x-x- $\phi 33/\phi 25$ Flexible mesh-reinforced tube

Note: Regarding requirement of solenoid valve, see ● Solenoid valve (SV1 to SV4).

Without head tank
(Manual cleaning, manual zero calibration)

F1: Zero turbidity filter 1 μ m
 BV2, 4, 9, 10, 11: Ball valve
 PR1: Pressure regulator
 NV1, 3: Needle valve

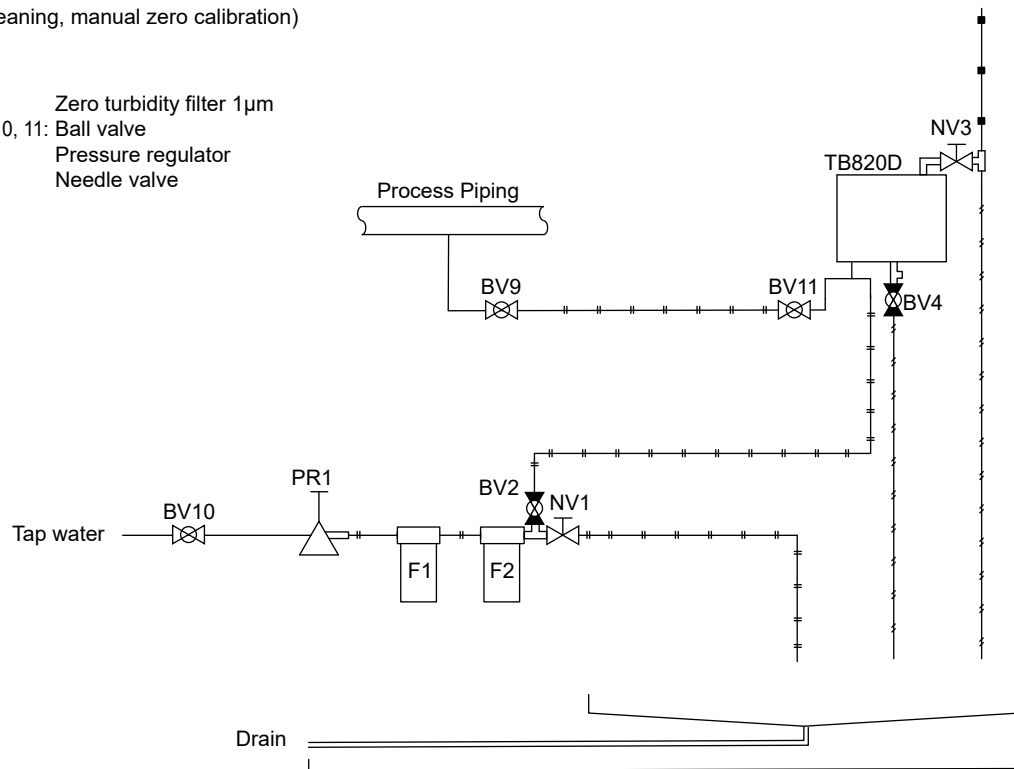

<PIPE> ———— $\phi 8/\phi 6$ Polyethylene tube
 ———— $\phi 12/\phi 9$ Polyethylene tube
 ———— $\phi 22/\phi 15$ Flexible mesh-reinforced tube